



RHINO-RACK

Pioneer Recovery Track Flat Bracket (43235)

Important: Please read these instructions carefully prior to installation. Please refer to your fitting instruction to ensure that the bracket is installed in the correct locations. Check the contents of kit before commencing fitment and report any discrepancies. Place these instructions in the vehicle's glove box after installation is complete.

Parts List

Item	Component Name	Qty.	Part No.
1	Recovery Bracket	2	CA1823
2	M10 x 100mm Hex Bolt	4	B259
3	M10 Spring Washer	4	W061
4	M10 Nut	4	N075
5	M6 x 16 Socket Head Screw	4	B031
6	M6 Spring Washer	4	W004
7	M6 x 12.5mm Flat Washer	4	W003
8	M6 Channel Nut	4	N002
9	M10 Turn Knob	4	M874
10	Torque Security Key	1	TOR-KEY-SXB
11	Instructions	1	R1203

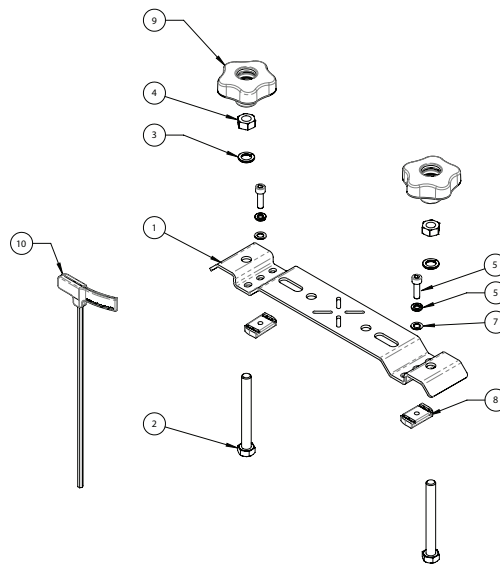

Tools required: 16mm spanner.

Recommendations:

Clean product prior to fitting the Pioneer Recovery Tracks Bracket. The recommended maximum number of recovery tracks fitted on a set of bracket is four.

Note for Dealers and Fitters:

It is your responsibility to ensure instructions are given to the end user or client. Rhino-Rack

3 Pike Street, Rydalmere,
NSW 2116, Australia.
(Ph) (02) 9638 4744
(Fax) (02) 9638 4822

Document No: R1203
Prepared By: Peter Luu
Authorised By: Chris Murty

Issue No: 02
Issue Date: 20/10/17

These instructions remain the property of RhinoRack Australia Pty. Ltd. and may not be used or changed for any other purpose than intended.

Instructions

1 Assemble the pin hardware as shown. Tighten in place. Torque 10-13Nm.

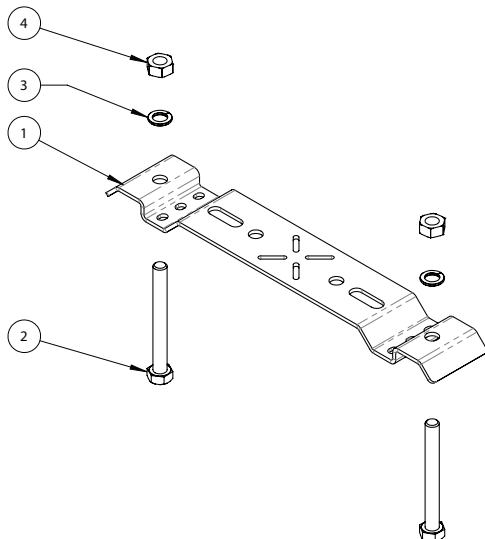

2 Assemble the M6 hardware as shown. Finger tighten only at this stage.

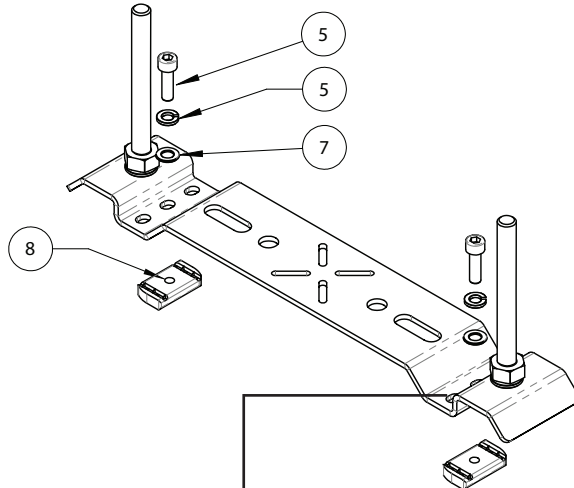

Any hole can be used to achieve minor adjustments in bracket positions.



Pioneer Recovery Track Flat Bracket (43235)

3 Assemble the nut and washers onto each of the bolts. Finger tighten. Do this for the 2nd bracket as well on the other side of the tray.

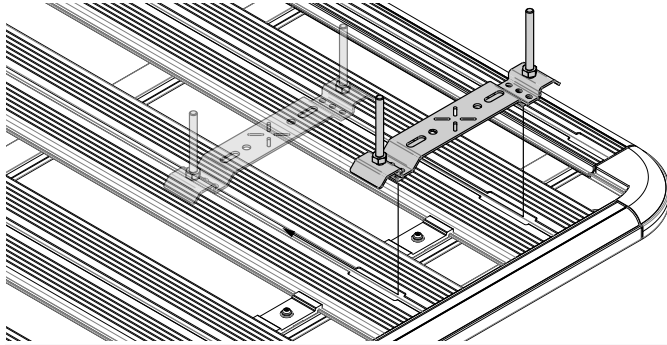

Note: Brackets can also be mounted in a sideways position.

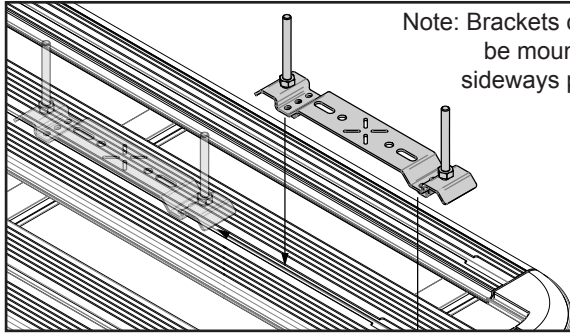

4 Adjust so the brackets are 890mm apart from the holes or place a recovery track on the side and use it as a guide to align the brackets.

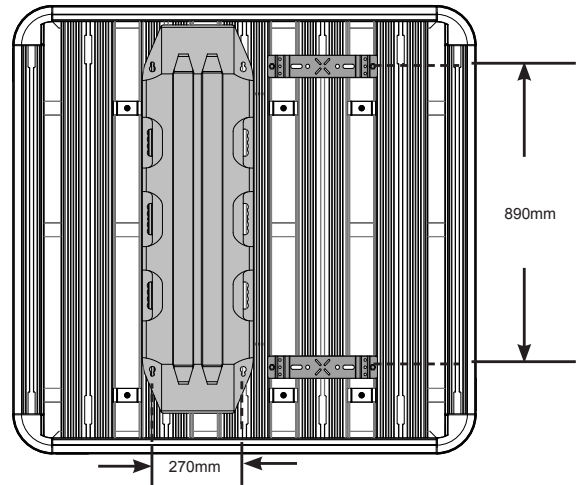

Once positioned correctly, remove tracks and tighten M6 hardware 5-6Nm.

5 Place the recovery track through the bolt threads onto the brackets. Make some adjustments to the bracket position if required. Tighten brackets in place.

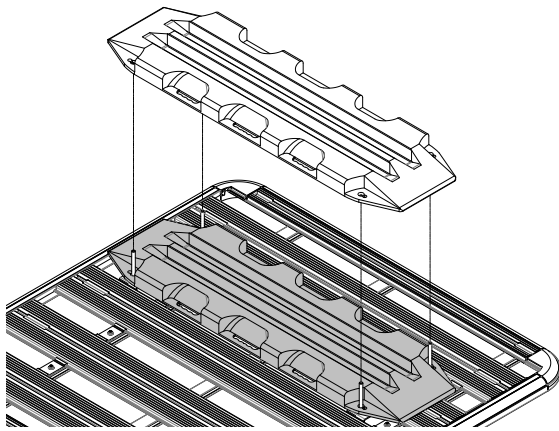

6 Lock the track in place by rotating all 4 knobs clockwise until it is tightened. Confirm by giving the tracks a small shake and make adjustments if required.

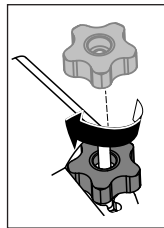

You might hear clicking sounds as you tighten. This is fine and is a good indicator that it is tightened or close to being fully tightened.

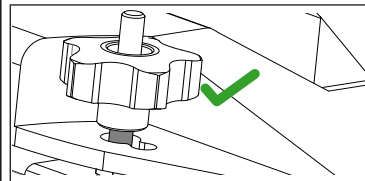

You will notice a gap between the knob and track once tightened. This is normal.

Optional

Users can purchase a Pioneer Cable Core Lockdowns (Part# 43205, 43206 or 43207) to safely secure their tracks to the tray.

