



FITTING INSTRUCTIONS

Part Number: **5438110**

Product Description: UNDER VEHICLE PROTECTION.

Suited to vehicle/s: NISSAN D40 THAILAND & SPANISH BUILD. V6 & 4CYL DEISEL

Please place these instructions in vehicle glove box when complete.

WARNING

REGARDING VEHICLES EQUIPPED WITH SRS AIRBAG:

When installed in accordance with these instructions, the vehicle protection panels do not affect operation of the SRS airbag.

ALSO, NOTE THE FOLLOWING:

- ◆ This product must be installed exactly as per these instructions using only the hardware supplied.
- ◆ Do not use this product for any vehicle make or model, other than those specified by ARB.
- ◆ Do not remove labels (if any) from this product.
- ◆ This product or its fixing must not be modified in any way.
- ◆ The installation of this product may require the use of specialized tools and/or techniques
- ◆ These instructions are correct as at the publication date. ARB Corporation Ltd. cannot be held responsible for the impact of any changes subsequently made by the vehicle manufacturer
- ◆ During installation, it is the duty of the installer to check correct operation/clearances of all components
- ◆ Work safely at all times
- ◆ Unless otherwise instructed, tighten fasteners to specified torque

ARB 4x4 ACCESSORIES

Corporate Head Office

42-44 Garden St
Kilsyth, Victoria
AUSTRALIA 3137

Tel: +61 (3) 9761 6622
Fax: +61 (3) 9761 6807

Australian enquiries
North & South American enquiries
Other international enquiries

sales@arb.com.au
sales@arb.com.au
exports@arb.com.au

www.arb.com.au

IMPORTANT INFORMATION. GENERAL CARE AND MAINTENANCE

By choosing ARB vehicle protection, you have bought a product that is one of the most sought after 4WD products in the world. Your underpanels are a properly engineered, reliable, quality accessory that represents excellent value.



- While these panels have been engineered for strength and functionality care and good judgment should be taken when traversing difficult off-road conditions to minimise damage to panels and vehicle.
- During servicing when panels are removed ensure fasteners are re-fitted to the correct torque values.
- Inspect panels visually on a regular basis. Dirt and foreign matter should be washed out to minimise build-up around hot components. **BE VERY CAREFULL** when removing foreign matter with hands while vehicle is hot or running. Replace any components as necessary. This service can be performed by your local authorized ARB Stockist.

FITTING REQUIREMENTS

REQUIRED TOOLS FOR FITMENT OF PRODUCT:

BASIC TOOL KIT	
OIL DRIP TRAY	

HAVE AVAILABLE THESE SAFETY ITEMS WHEN FITTING PRODUCT:

Protective eyewear 	Hearing protection 
--	--

NOTE: 'WARNING' notes in the fitting procedure relate to OHS situations, where to avoid a potentially hazardous situation it is suggested that protective safety gear be worn or a safe work procedure be employed. If these notes and warnings are not heeded, injury may result.

FASTENER TORQUE SETTINGS:

SIZE	Torque Nm	Torque lbft
M6	9Nm	7lbft
M8	22Nm	16lbft
M10	44Nm	32lbft
M12	77Nm	57lbft

PARTS LISTING

APPLICATION.	PART NO.	QTY	DESCRIPTION
FIT FRONT PANEL	6522923	1	FRONT PANEL ASSY
	3758409	1	FRONT BRACKET BULLBAR V6
	3757965	1	FRONT MOUNT
	3194154	2	PLATE CAGE NUT
	3758104	1	BRACKET BUMPER MOUNT
	3758105R	1	BRACKET RHS MOUNT
	3758105L	1	BRACKET LHS MOUNT
	6151095	2	BOLT M12 X 1.25 X 35
	4581064	2	SPRING WASHER M12
	4581049	2	FLAT WASHER M12
	6151357	2	BOLT M10 SEMS
	6151321	2	NUT FLANGE M10
	6151022	4	BOLT M8 X 1.25 X 35
	4581046	4	WASHER SPRING M8
	4581044	4	FLAT WASHER M8
	6151303	5	CAGE NUT M8
	6151180	6	BOLT M6 X 20
	6151042	6	WASHER SPRING M6
	4581084	2	WASHER PANEL M6
	6151046	2	WASHER FLAT M6
4581072	2	WASHER FLAT M6 X 16	
6151128	2	NUT FLANGE M6	
6151300	6	CAGE NUT M6	
FIT SUMP PANEL	6522879	1	SUMP PANEL ASSY
	3757968	1	MOUNTING BRACKET
	6151022	4	BOLT M8 X 1.25 X 35
	4581046	4	SPRING WASHER M8
	4581044	4	FLAT WASHER M8
	6151303	3	CAGE NUT M8
FIT TRANSMISSION PANEL	6522767	1	TRANSMISSION PANEL ASSY
	3194153	2	CAGE NUT PLATE
	4721743	2	50MM SPACER TUBE
	6151022	3	BOLT M8 X 1.25 X 35
	6151434	2	CAP SCREW M8 X 1.25 X 70
	4581046	5	SPRING WASHER M8
	4581044	5	FLAT WASHER M8
	6151303	3	CAGE NUT M8
	6151132	2	FLANGE NUT M8
FIT TRANSFER CASE GUARD	6522922	1	T/CASE GUARD ASSY

FITTING PROCEDURE



1. Remove O.E stone shield, tow hook and two bottom bolts from ARB panel. Loosen the top four panel bolts but do not remove. Set aside hardware and hook for later use. If no bar is fitted remove bottom plastic section of bumper and retain for later use.



2. Fit front mounting bracket to cross-member that holds the sway bar using M8 x 35 bolts, spring washers and flat washers. On vehicles built in Thailand it will be necessary to use M8 cage nut plates fed through access holes in chassis. Bend plates to shape.

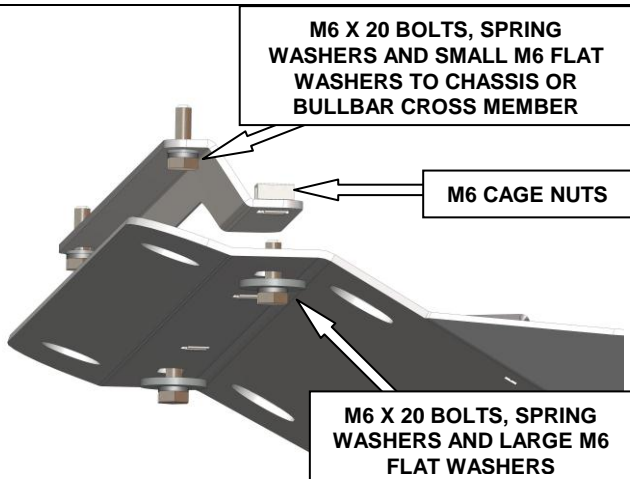

3. **For fitting to late model vehicles with bullbar or any vehicles with O.E bumper:** Secure front mount bracket to vehicle, and after step 7, to front panel using M6 hardware as shown.

NOTE: Not required for V6 diesel with bullbar and pre-2011 4cyl.

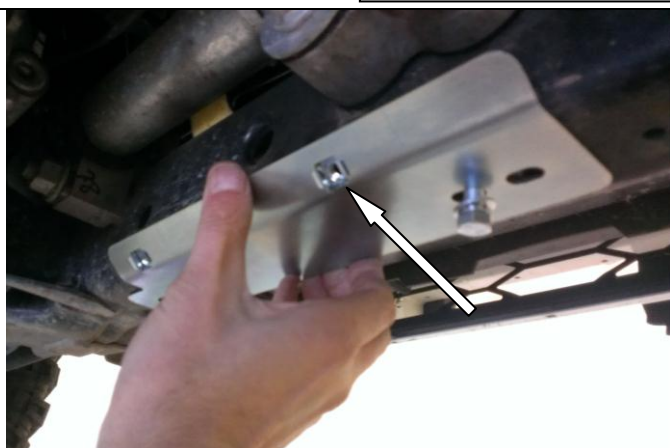

4. Fit three M8 cage nuts to mounting bracket.

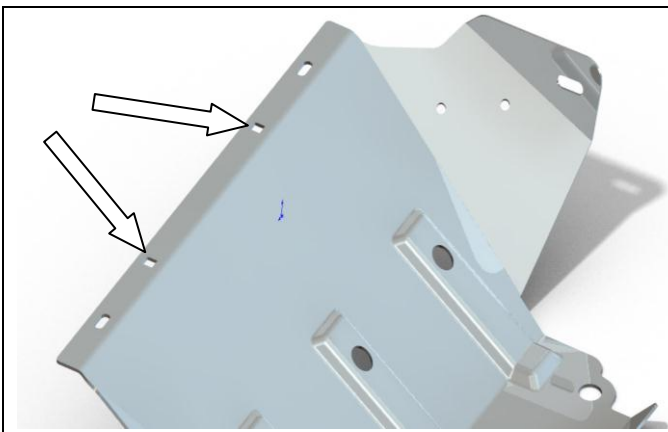

5. If O.E bumper is being retained fit 2 x M6 cage nuts as shown to top surface of front panel.

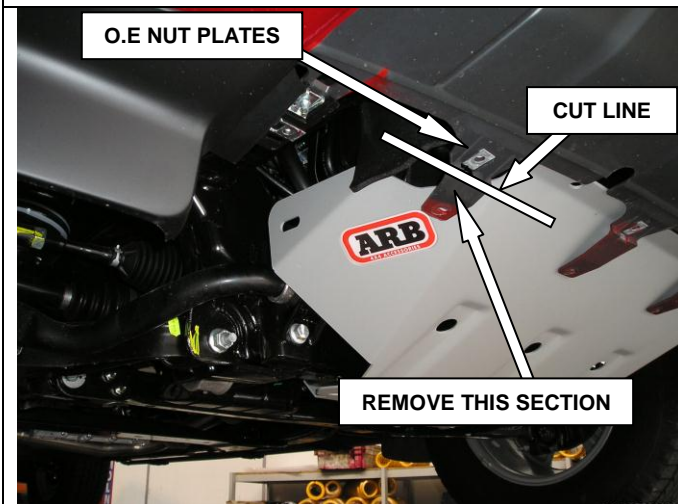

6. If retaining the bumper cut the four lower tabs as shown keeping the section that contains the O.E nut plates. Remove the two INNER O.E captive nut plates and leave the outer plates in place.



7. If bullbar is fitted carefully loosen off the main chassis brackets. Slide side mounting brackets onto bottom bolts (tabs face inwards and towards the rear). Leave loose for now. If no bullbar is fitted attach using original hook and fasteners, M12 bolts, spring washers and flat washers. Leave finger tight.



8. Lift front panel assembly into place making sure brackets fitted in step 7 are on inside of panel. Secure front edge of panel to bullbar cross member or mounting bracket as described in step 3. Bullbar stone shield must sit below panel. Pre 2011 models fasten directly to bullbar cross member. Leave finger tight.



- Attach rear of panel to mounting bracket using one M8 x 35 bolt, spring washer and flat washer in the centre position only. Leave bolt finger tight.

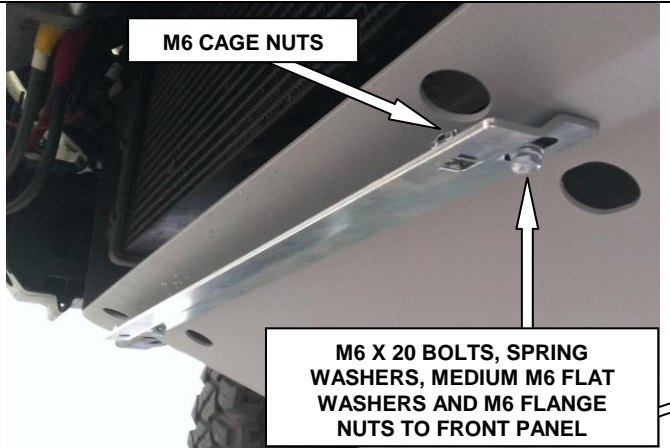

- For V6 diesel models with bullbar: Attach V6 stone shield mounting bracket to panel using fasteners as shown. Re fit stone shield as shown below and secure using M6 fasteners provided.

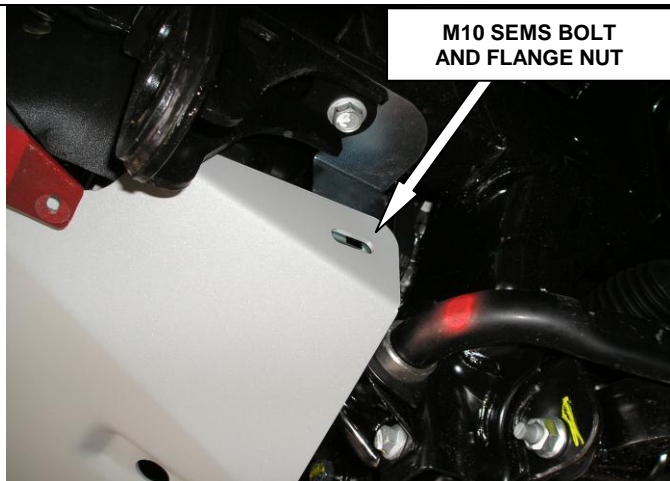
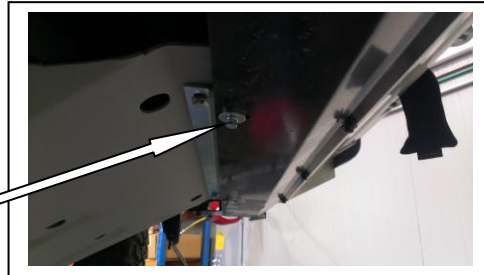

- Make sure side brackets sit on inside edge of front panel. Secure using 1 x M10 SEMS bolts and M10 flange nut per side. Once this has been completed tighten bolts to settings below ensuring that access to the two rear outer M8 cage nuts is possible when fitting sump panel.

 M6 - 9 Nm.
  M8 - 22 Nm.

 M10 - 44 Nm.
  M12 - 77 Nm.

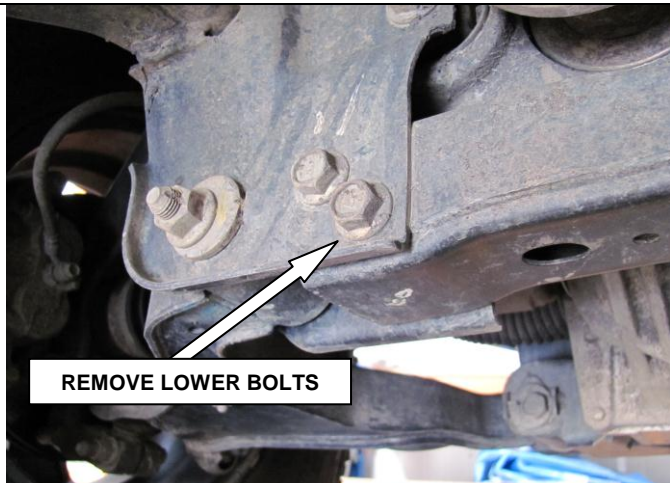

- Fitting sump panel. Remove the two lower bolts from rear face of cross member and retain.

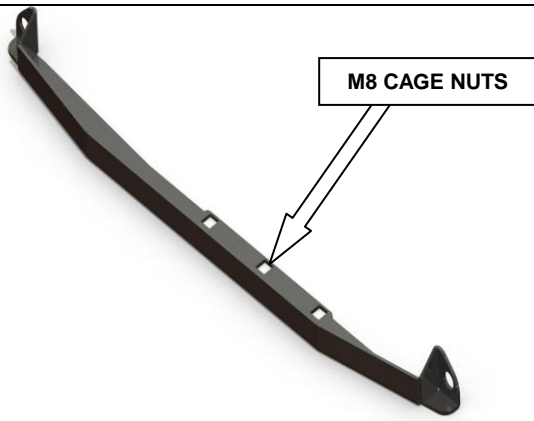

13. Place 3 x M8 cage nuts onto bracket and mount to rear face of cross member using bolts removed in step 10. Tighten these bolts now.



M10 - 44 Nm.



14. Place sump panel in position and attach to the rear bracket using three M8 x 35 bolts, spring washers and flat washers. Leave finger tight.



15. Attach sump panel to front panel using two M8 x 35 bolts, spring washers and flat washers through access holes as shown. Leave finger tight.

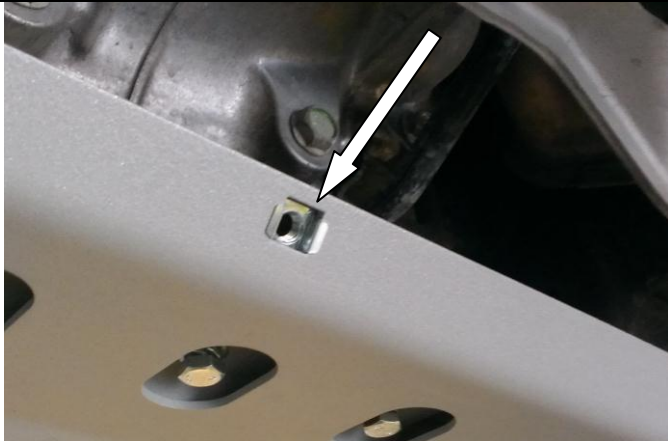

16. Fit one M8 cage nut to the centre point of sump panel as shown in the photo.

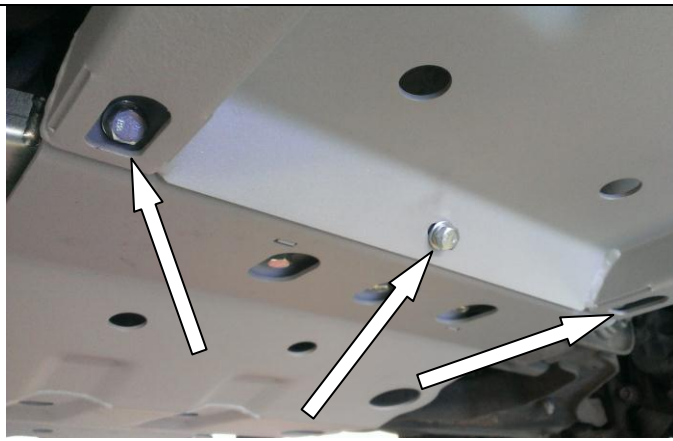

17. Attach to sump panel using one M8 x 35 bolt, spring washer and flat washer for the centre point and two M8 x 35 bolts, spring washers, flat washers and flange nuts on outer holes. Leave finger tight.

SPACER TUBES AND NUT PLATES ON TOP

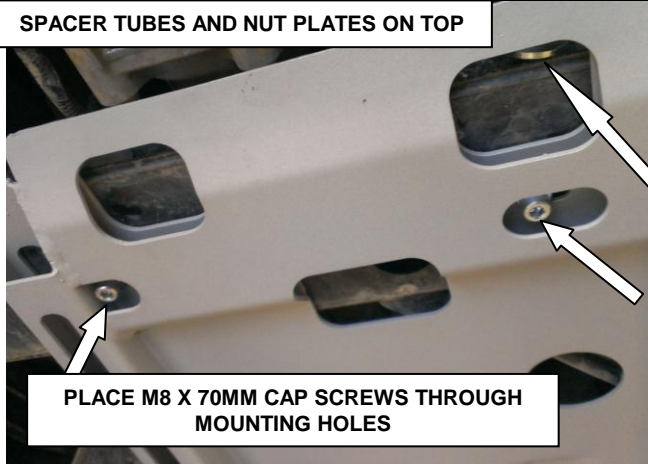

18. Place M8 spring washers and flat washers on the two M8 x 70 cap screws and pass up through mounting holes in transmission panel. Through the top hole in vehicle cross member place a 49mm spacer into the cross member and over the cap screw. Secure using large captive nut plates and M8 cage nuts. Tighten all bolts when done.

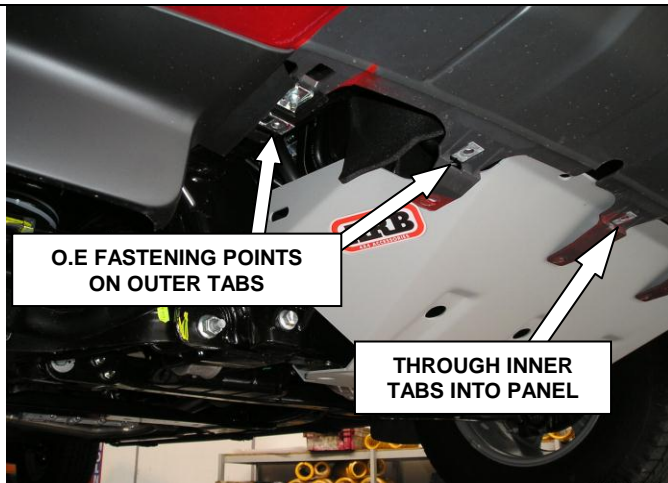
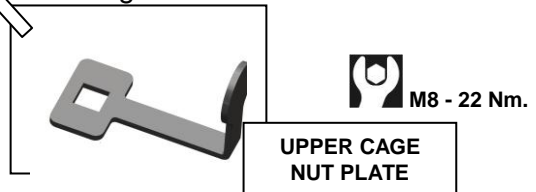

19. Fit front skirt back to vehicle. Fastener must go through two centre tabs into cage nut in panel. Outer tabs secure to O.E points.



20. Place a drip-tray under the transfer case and remove six bolts as shown in the photo. **Note:** It is likely that oil will not leak from the transfer case but it would be wise to have a drip-tray in position.

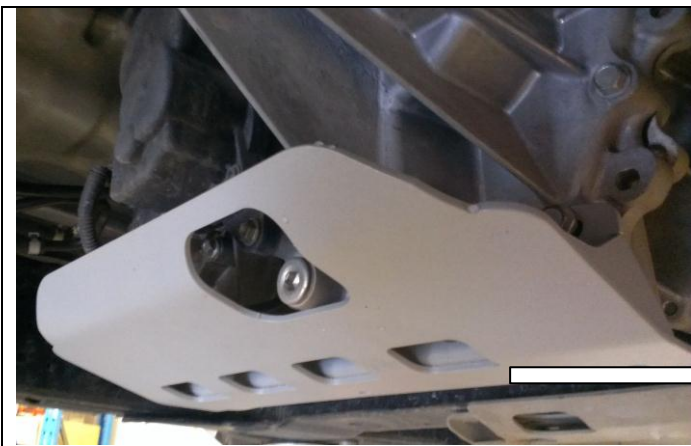

21. Place the transfer case guard in place and attach using original bolts.



M10 - 44 Nm.

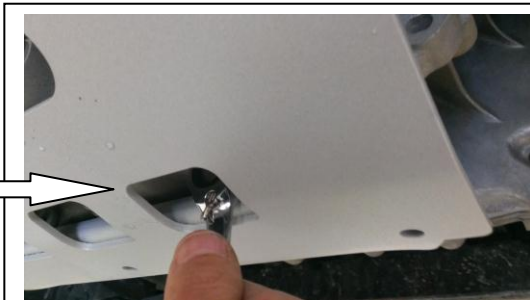

FITTED PRODUCT

