



**ARMAX**

# SS122HP

SAFARI ARMAX SNORKEL  
TOYOTA HILUX (KUN26R Series)  
3.0L Turbo Diesel D-4D (1KD-FTV Engine)  
Built: 03/2005 – 06/2015 (Pre & Post Facelift Models)



15/03/2017

## Parts List

ITEM	PART NO.	DESCRIPTION	QTY
1	320-133-600	BODY - SNORKEL (SS122HP)	1
2	000-135-960	4" AIR RAM ASSEMBLY	1
3	320-032-600	BRACKET - UPPER MOUNTING	1
4	000-002-100	BOLT - HEX - 6mm x 1.0 x 14mm (SEMS)	2
5	000-951-300	SCREW - S/T - 4.2mm x 16mm - S/S	3
6	000-960	INSERT - PLASTIC	3
7	000-110	STUD - 8mm x 1.25 x 25mm - S/S	6
8	000-311-300	WASHER - BODY - 8mm x 30mm - S/S	6
9	000-205-300	NUT - NYLOC - 8mm x 1.25mm - S/S	6
10	320-024-600	HOSE - AIR ENTRY	1
11	320-025-600	PLATE - HOSE SUPPORT	1
12	000-958-175	POP RIVET- 4.0mm x 17mm	12

13	000-300-350	WASHER - BODY - 4.0mm x 12mm S/S	13
14	320-967-600	PLATE - INNER GUARD SUPPORT	1
15	000-1020-300	BOLT - B/H CAP SCREW 5.0mm x 0.8 x 12mm S/S	9
16	000-320-350	WASHER - BODY 5.0mm x 15mm S/S	18
17	000-221-300	NUT - NYLOC 5.0mm x 0.8mm S/S	9
18	000-1912	CLAMP - HOSE - 110/130mm	1
19	000-1931/B	CLAMP - HOSE - SIZE 64 (BLACK)	1
20	320-217-600	TEMPLATE - AIR CLEANER HOUSING	1
21	320-017-700	TEMPLATE - INNER GUARD PANEL	1
22	320-017-600	TEMPLATE - GUARD PANEL	1
23	320-016-600	INFILL - FOAM (Snorkel Body) Pre-Facelift Models Only	1



# SS122HP

SAFARI ARMAX SNORKEL  
TOYOTA HILUX (KUN26R Series)  
3.0L Turbo Diesel D-4D (1KD-FTV Engine)  
Built: 03/2005 – 06/2015 (Pre & Post Facelift Models)

## Installation Guide

### Fitment to:

- Right Hand Side

### Fitting Time:

- 210min

### Special Tools:

- Body Saw (Reciprocating)
- 90 deg Drill
- Step Drill
- 4.5mm, 5.5mm Drill Bits
- Files
- Pop Rivet Gun
- Sikaflex 227 Adhesive Sealant
- Loctite 243 (thread lock)
- Masking Tape
- Touch-up paint

**Prior to commencing the installation, it is the installer's responsibility to verify that all components and particularly the template (Item 22) are correct.**

**1** Remove the following in accordance with the factory service manual:

- Air Cleaner Assembly
- RHS Mud Flap
- RHS Guard Liner
- RH Guard mounted indicator (if fitted to vehicle)

**2**

Remove and discard

- Air intake ducting



3

Align the guard panel template (Item 22) with the upper and rear edges of the RHS guard panel as shown.

Tape the template to the guard panel with masking tape.

Mark all hole positions and the cut-out section with a felt tip pen.

Remove the template.

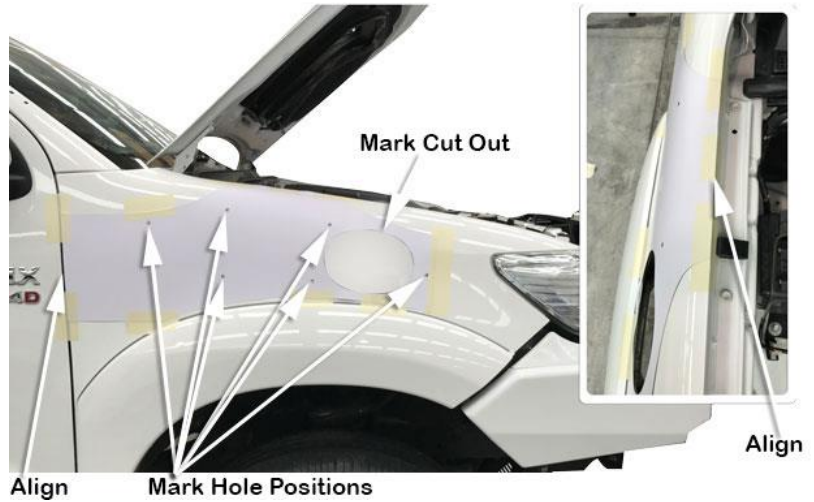

4

Drill a pilot hole for each of the marked hole positions.

Use a step drill to drill the six mounting holes to 16mm diameter.

Drill 2 or 3, 10mm diameter holes in the cut-out section for a start/stop point for the body saw, using the body saw cut the main hole in the guard panel as marked from the template cut-out in step 3.

Deburr and paint all holes.

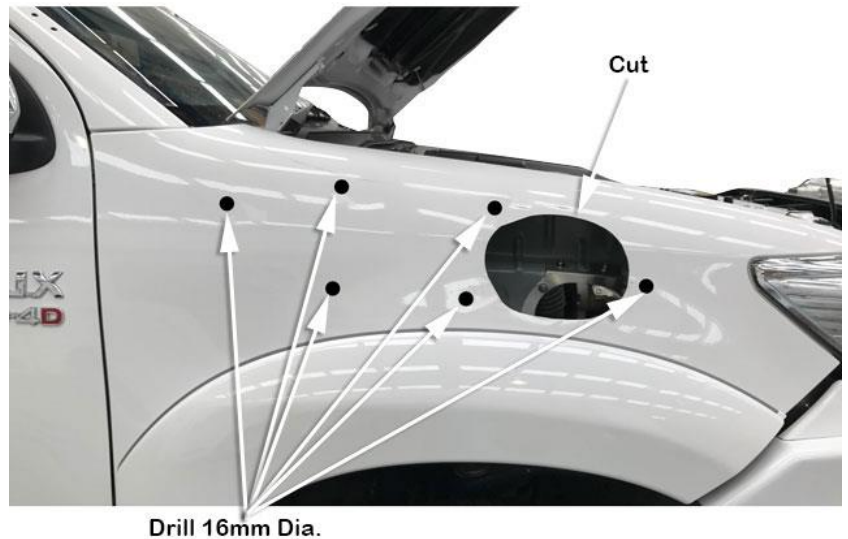

5a

**Pre & Post Facelift Models:**

Install the upper mounting bracket (Item 3) to the snorkel body (Item 1) with hex bolts (Item 4).

Apply Loctite 243 to each of the stainless steel mounting studs (Item 7) and install the studs finger tight into the snorkel body (Item 1) mounting inserts as shown.

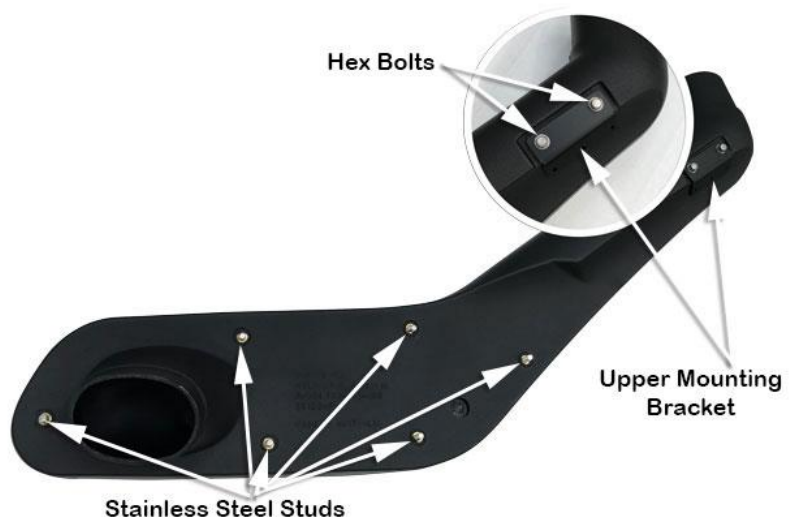

5b

**Pre-Facelift Models Only**  
**Built: 03/2005 – 07/2011:**

Remove the self adhesive backing from the foam infill (item 23).

Install the foam infill over the front mounting stud and align the foam infill piece to the front of the snorkel body.



6

Place a strip of masking tape along the A-pillar panel.

Carefully install the snorkel body (Item 1) to the guard panel.

With the snorkel body correctly positioned on the vehicle, accurately mark the position of the upper mounting bracket (Item 3) onto the masking tape.

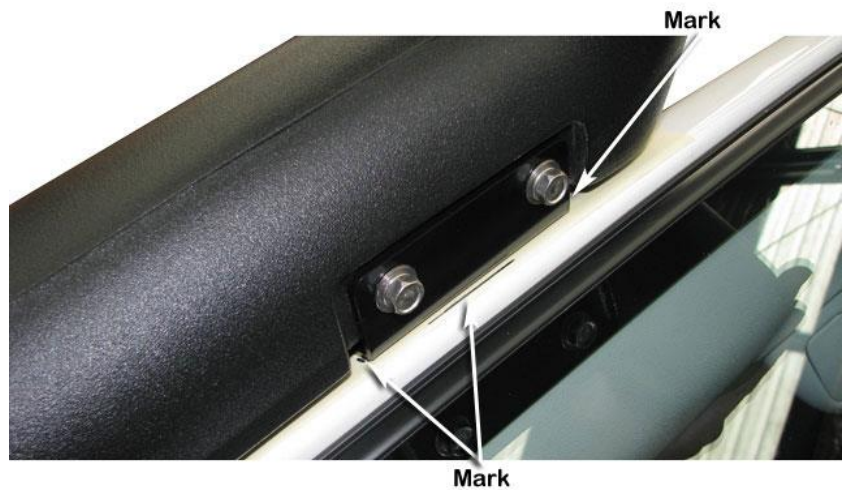

7

Remove the snorkel body (Item 1) from the vehicle and remove the upper mounting bracket (Item 3) from the snorkel body.

Position the upper mounting bracket (Item 3) onto the A-pillar and align the bracket with the marked bracket outline. Mark the three mounting hole positions with a felt tip pen.

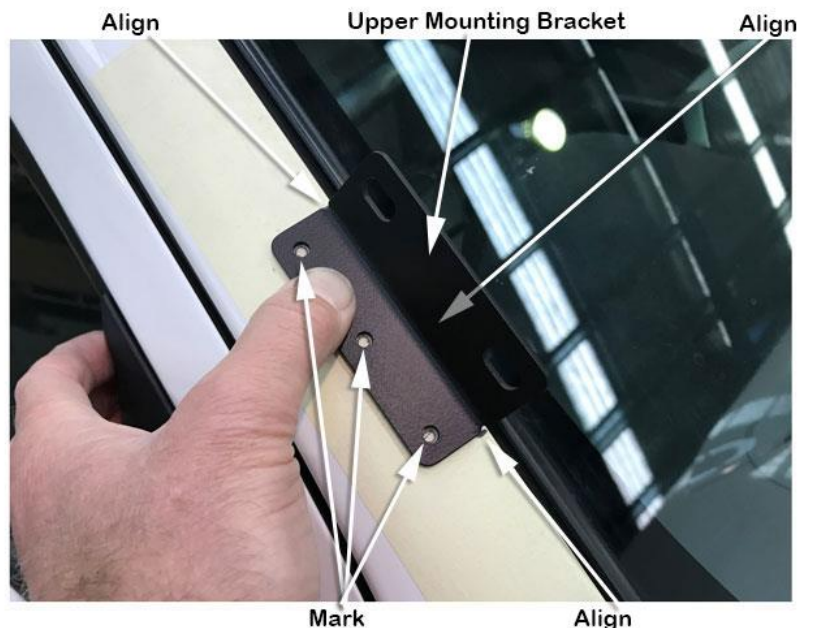

Drill a pilot hole at each of the three marked hole positions. Drill each hole position to 8mm diameter with a step drill or 8mm drill bit.

Deburr and paint holes.



Drill 8mm Dia.

Marked Hole Positions

Install the plastic inserts (Item 6) into the 8mm diameter holes in the A-pillar.

Secure the upper mounting bracket (Item 3) to the A-pillar with three self-tapping screws (Item 5).

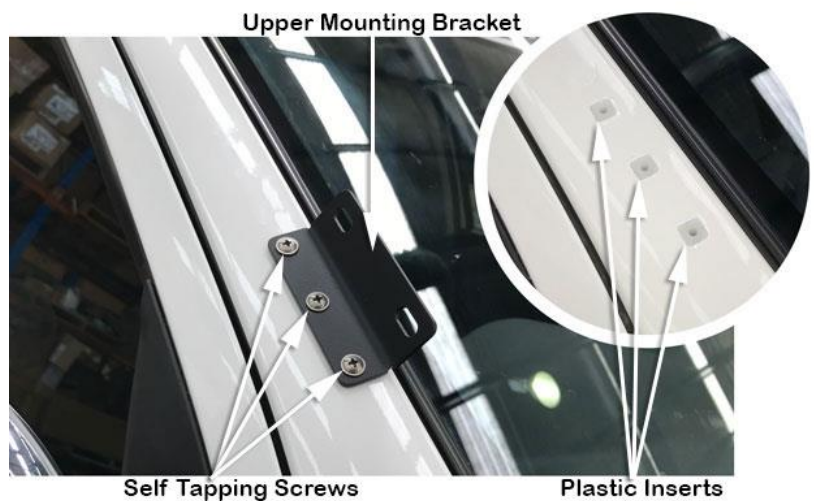

Upper Mounting Bracket

Self Tapping Screws

Plastic Inserts

Un-clip the wiring loom, bonnet release cable and remove the M6 earth bolt from the inner guard panel.

Align the inner guard template (item 21) to the earth bolt hole, wiring loom and bonnet cable clip holes. With the template correctly aligned install the earth bolt and tape the template to the inner guard with masking tape as shown.

Mark all nine hole positions and the main inner guard hole.

Remove the template.

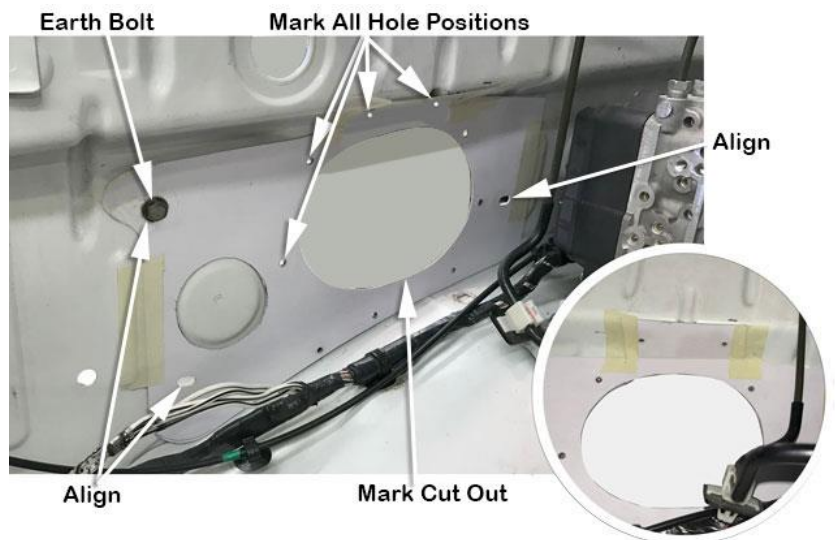

Earth Bolt

Mark All Hole Positions

Align

Align

Mark Cut Out

Drill a pilot hole for each of the marked hole positions (use the 90 deg drill to drill the two upper holes), drill each hole to 5.5mm.

Using the body saw cut the main hole in the inner guard panel as marked.

Trial fit the inner guard support plate (item 14), if necessary re-drill any of the mounting holes or file the main hole to suit the plate.

De-burr and paint all holes.

*Hint: Either use a long series 5.5mm drill bit to drill holes or drill as many holes as possible, install the support plate and drill from the inner guard side, drill through the support plate and through the inner guard panel using a 90 deg drill.*



Apply Sikaflex 227 adhesive sealant to the inner guard support plate (item 14) and install the plate to the inner guard panel, secure to the inner guard panel with 5mm x 12mm Button Head bolts (item 15), 5mm x 15mm body washers (item 16) and 5.0mm nyloc nuts (item 17) as shown.

Clean up any excess Sikaflex 227 adhesive sealant to ensure a neat finish.



13

Drill out the three pop rivets holding the cyclonic deflector in the air cleaner base (hold the back of the pop rivets with a pair of pliers to prevent them from spinning whilst drilling out the pop rivets).

Remove and discard the cyclonic deflector.



14

Mark around the inlet snout as shown.





Using the body saw carefully cut off the inlet snout of the air cleaner base.



Using the body saw remove the corner ribs of the air cleaner housing mounting bracket as shown.

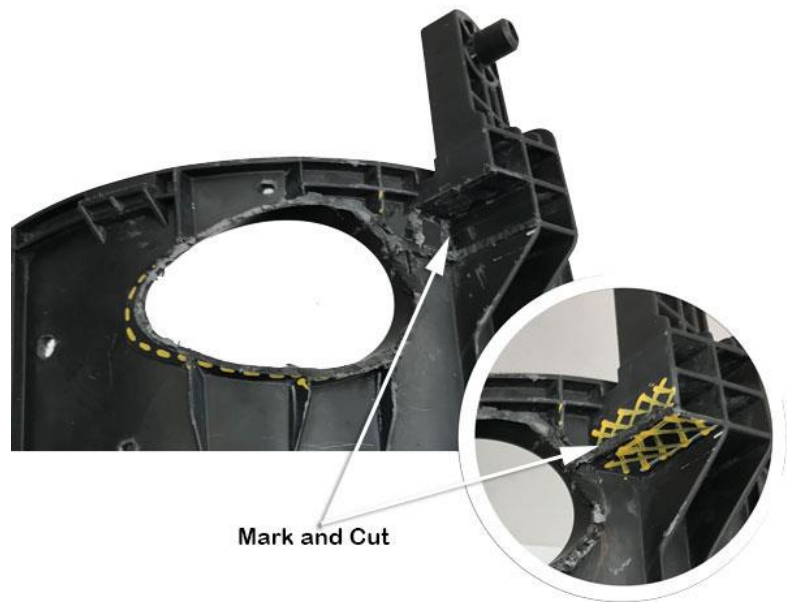

Apply masking tape to the inside of the air cleaner housing, align the air cleaner housing template (item 20) to the two upper pop rivet holes (install two pop rivets) and the top edge of the air cleaner housing as shown.

With the template correctly aligned, tape to the air cleaner housing with masking tape.

Mark all eleven hole positions and the air cleaner housing main hole.

Remove the template.

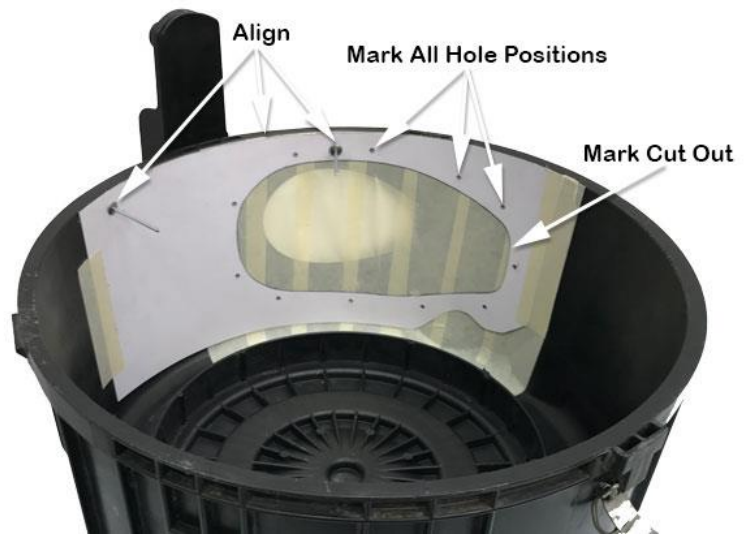

Drill a pilot hole for each marked hole position, using the 4.5mm drill bit, drill the eleven holes.

Using the body saw cut the main hole in the air cleaner housing



Using a file or die grinder clean-up the cut hole in the air cleaner.

Neatly remove the marked air cleaner ribs as shown.

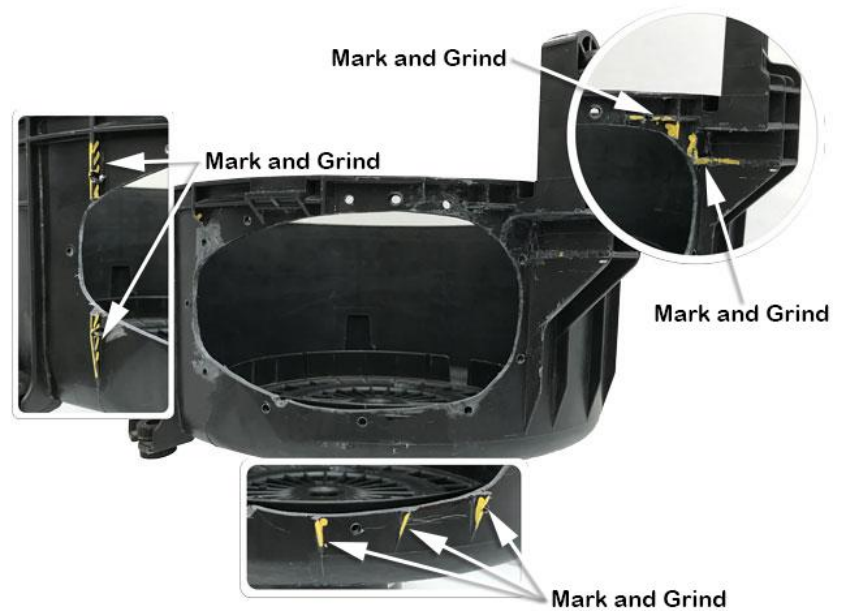

Trial fit the air entry hose (item 10), install the support plate (item 11) and all eleven pop rivets (item 12), if necessary re-drill any holes that are not correctly align

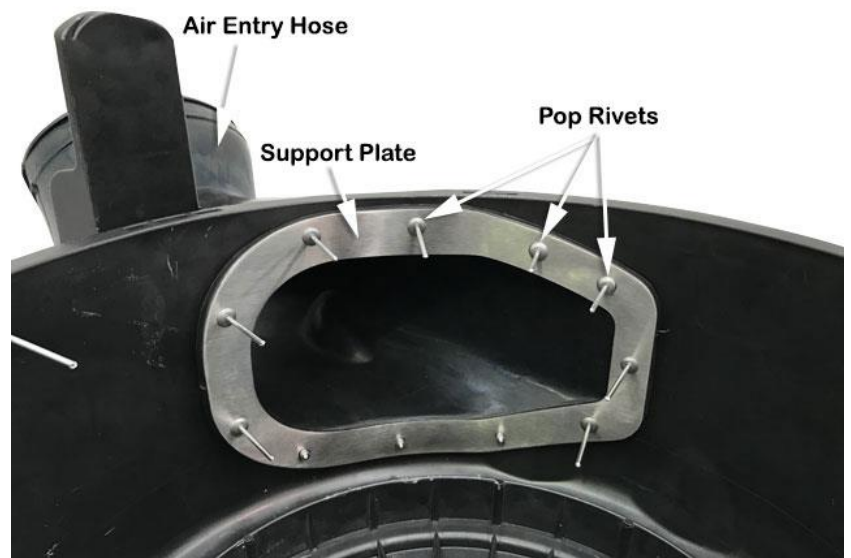

Apply Sikaflex 227 adhesive sealant to the air entry hose (item 10) sealing flange, install the hose to the air cleaner housing install the support plate (item 11), pop rivets (item 12), note the orientation of the three lower pop rivets with body washers (item 13) installed, install a body washer to the remaining eight pop rivets.

With all of pop rivets and body washers installed, secure the pop rivets using the pop rivet gun.

Clean up any excess Sikaflex 227 adhesive sealant to ensure a neat finish.



Install a pop rivet (item 12) with body washer (item 13) through the hole in the air cleaner housing as shown, install a second body washer to the pop rivet, using the pop rivet gun secure the pop rivet with body washers installed.

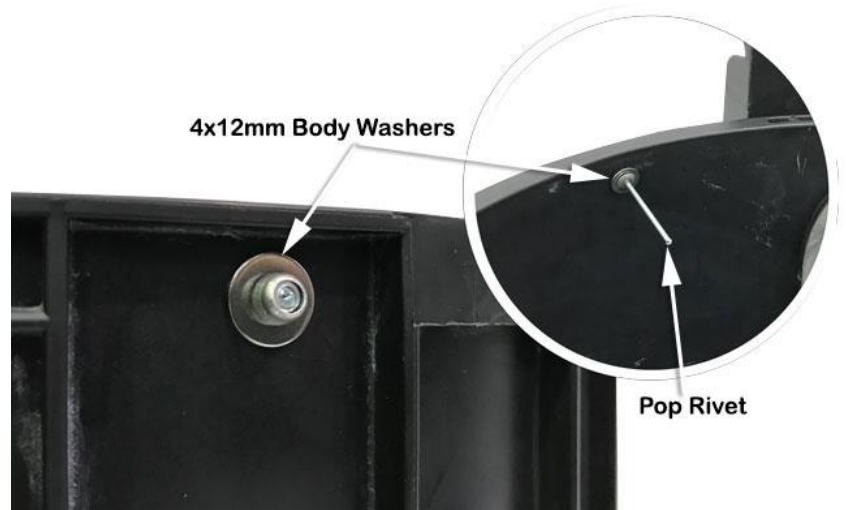

23

**INSTALLER OPTION :**

The air cleaner housing base contains a drain valve as shown. The drain valve can permit water to enter the air intake.

Safari advises that the drain valve should be sealed to ensure a watertight installation.



24

Install the air cleaner base with the air entry hose installed, through the hole in the inner guard panel.

*Hint: Squash and tape the end of the air entry hose for easier installation of the air cleaner housing.*



**Air Cleaner Base**

25

Loosely install a 110/130mm hose clamp (item 18) to the air entry hose (item 10).

*Note: Hose clamp orientation.*



**110/130mm Hose Clamp**

**Air Entry Hose**

Carefully install the snorkel body (Item 1) to the guard panel, guiding the snorkel body snout into the air entry hose (item 10), align the snorkel body to guard panel and upper mounting bracket.

When correctly aligned, fasten the snorkel body to the guard panel with body washers (Item 8) and nyloc nuts (Item 9).

Fasten the snorkel body to the upper mounting bracket with hex bolts (Item 4).

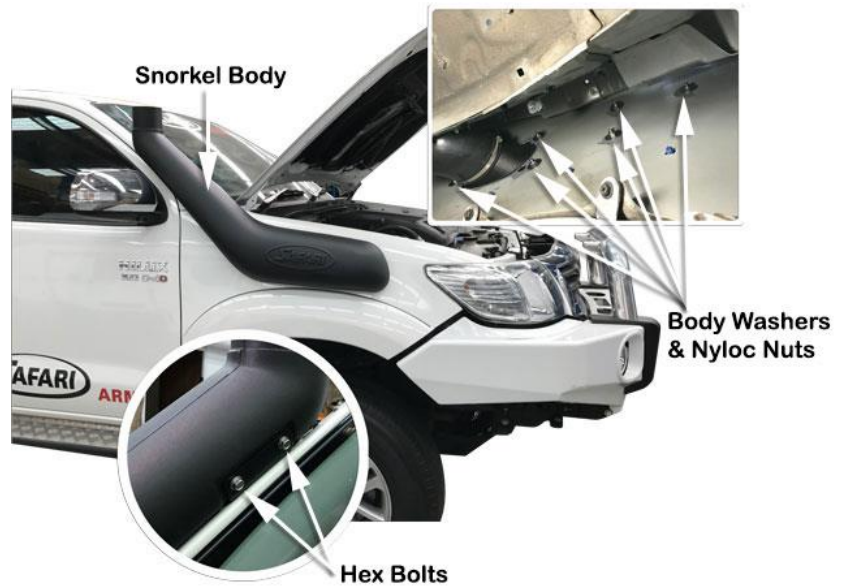

Align the air entry hose (item 10) for best fitment (*Ensure the air entry hose is installed hard up against the shoulder of the snorkel body outlet*), correctly position the 110/130mm hose clamp (item 18), tighten the hose clamp.



28

Loosely install the black hose clamp (Item 19) to the base of the air ram assembly (item 2).

Install the air ram onto the snorkel body (item 1).

Align the air ram assembly and tighten the black hose clamp (item 19).



29

Install the guard mounted indicator (if fitted to vehicle), guard liner, mud flap, air cleaner element, air cleaner lid, reconnect sensor wiring and any other items that may have been removed during the snorkel installation process.

30

**N.B: It is the installer's responsibility to ensure that all connections are water tight.**