

# SS420HF SAFARI V-SPEC SNORKEL

Toyota FJ Cruiser 2010 onwards  
4.0L V6 Petrol (1GR-FE Engine)



27/06/2011

## Parts List

ITEM	PART NO.	DESCRIPTION	QTY
1	340-133-000	BODY - SNORKEL (SS410HF)	1
2	000-135-800	3 ½" AIR RAM ASSEMBLY	1
3	340-032-000	BRACKET - UPPER MOUNTING	1
4	000-002-100	BOLT - HEX - 6mm x 1.0 x 14mm (SEMS)	3
5	000-951-300	SCREW - S/T - 4.2mm x 16mm - S/S	3
6	000-960	INSERT - PLASTIC	3
7	000-110	STUD - 8mm x 1.25 x 25mm - S/S	8
8	000-311-300	WASHER - BODY - 8mm x 30mm - S/S	8
9	000-205-300	NUT - NYLOC - 8mm x 1.25mm - S/S	8
10	340-024-400	HOSE - AIR ENTRY	1
11	000-910	CLAMP - HOSE - 90/110mm	1
12	000-1911	CLAMP - HOSE - 100/120mm	1
13	340-704-000	BLANK-OFF - INDICATOR	1
14	000-093-300	BOLT - B/H CAP SCREW 4mm x 0.7mm x 12mm - S/S	2
15	000-300-350	WASHER - BODY 4mm x 11mm - S/S	2
16	000-223-300	NUT - NYLOC - 4mm x 0.7mm - S/S	2
17	000-914/B	CLAMP - HOSE - SIZE 56 (BLACK)	1
18	340-017-200	TEMPLATE - INDICATOR RELOCATION	1
19	340-017-000	TEMPLATE - GUARD PANEL	1

## Installation Guide

### Fitment to:

- Right Hand Side

### Fitting Time:

- 120min
- +30min Aust Spec

### Special Tools:

- 105mm hole saw
- Step drill
- Masking Tape
- Body Saw (reciprocating)
- Loctite 243 (thread lock)
- Touch-up paint
- Files
- 4.5mm Drill Bit

**Prior to commencing the installation, it is the installer's responsibility to verify that all components and particularly the template (Item's 18 & 19) are correct.**

**1** Remove the following in accordance with the factory service manual:

- RHS mud flap
- RHS guard liner
- Air cleaner assembly
- RHS guard mounted indicator (Australian specification vehicles only)

**2**

Remove and discard the air intake duct from the inner guard and the air cleaner inlet adaptor.



3

Align the guard panel template (Item 19) with the upper and rear edges of the RHS guard panel. Tape the template to the guard panel with masking tape.

Mark all hole positions with a felt tip pen.

Remove the template.

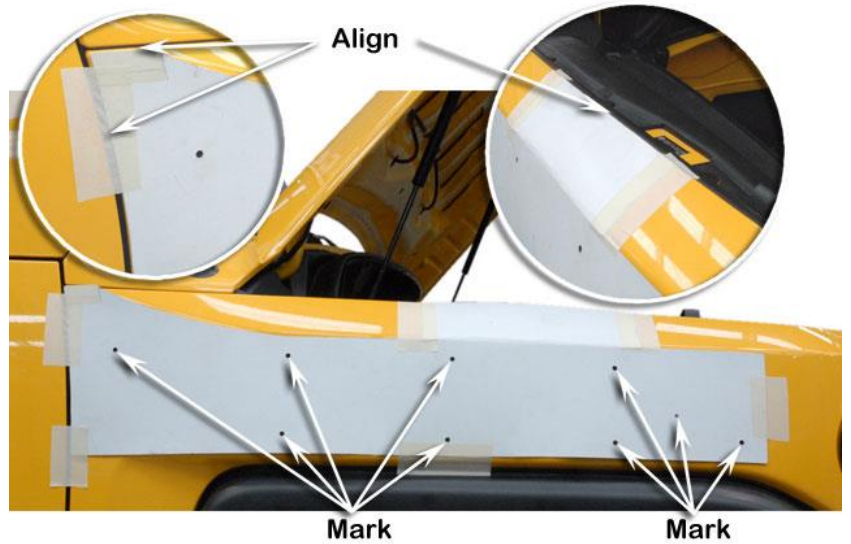

4

Drill a pilot hole for each of the marked hole positions.

Use a 105mm diameter hole saw to drill the snorkel body outlet hole position.

Use a step drill to drill the eight mounting holes to 16mm diameter.

Deburr and paint all holes to prevent rust.

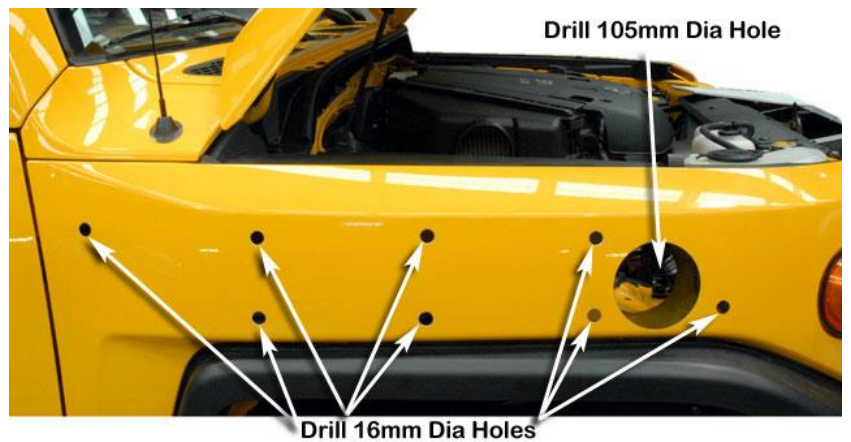

5

**Australian Vehicles Only:**

Australian specification vehicles are equipped with a guard mounted indicator which needs to be relocated.

Place a strip of masking tape on the lower section of the guard panel as shown.

Align the indicator relocation template (item 18) to rear edge of the RHS guard panel and to the standard indicator hole. Tape the template to the guard panel with masking tape.

Use a fine point pen to mark the indicator hole cut out onto the masking tape and the two hole positions at the standard indicator hole as shown.

Remove the template.

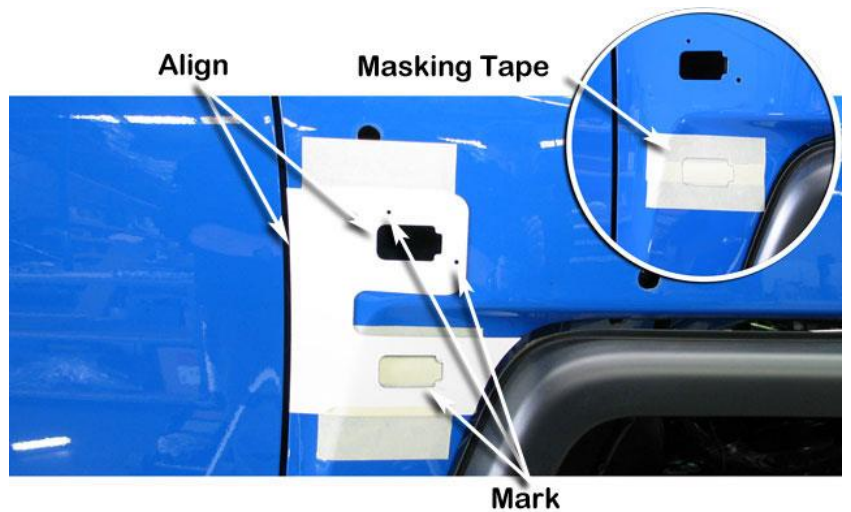

6

**Australian Vehicles Only:**

Using the body saw, carefully cut out the new indicator hole, use a file to shape the hole correctly, trial fit the indicator to ensure the indicator locates correctly into the hole.

Drill a pilot hole at each of the two marked hole positions. Drill each hole position to 4.5mm diameter.

Position the indicator blank-off plate (item 13) into the standard indicator hole and mark the two hole positions onto the plate, remove the plate and drill the two marked hole positions to 4.5mm diameter.

De-burr and paint holes to prevent rust.

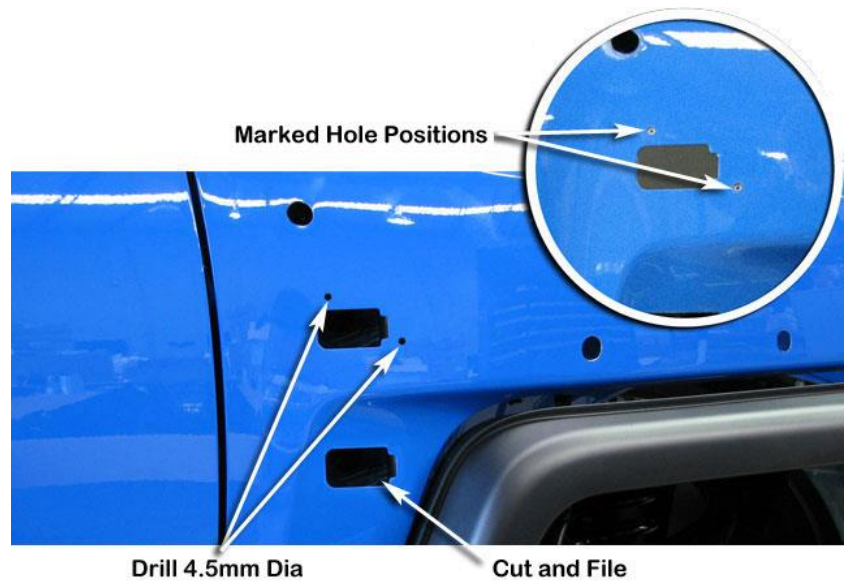

7

**Australian Vehicles Only:**

Install the indicator blank-off plate into the standard indicator hole and secure to the guard panel with B/H cap screws (item 14), body washers (item 15) and nyloc nuts (item 16) installed as shown.

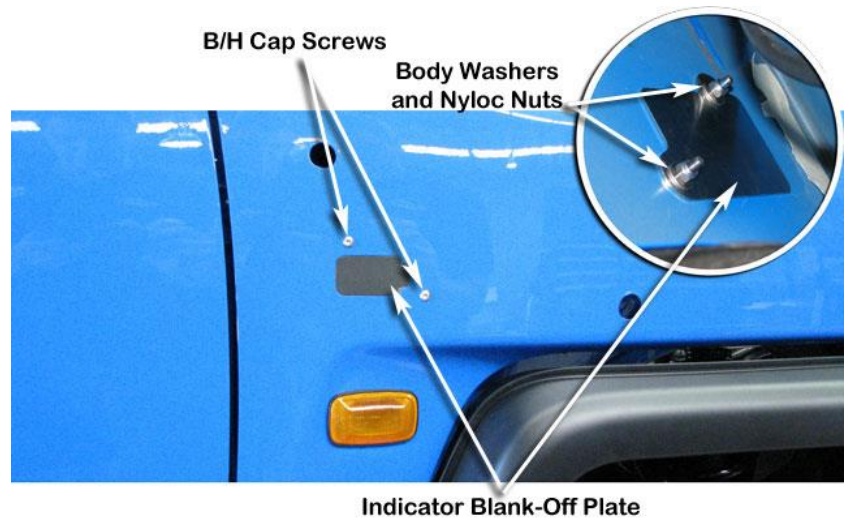

8

Install the upper mounting bracket (Item 3) to the snorkel body (Item 1) with hex bolts (Item 4).

Apply Loctite 243 to each of the stainless steel mounting studs (Item 7) and install the studs finger tight into the snorkel body (Item 1) mounting inserts.

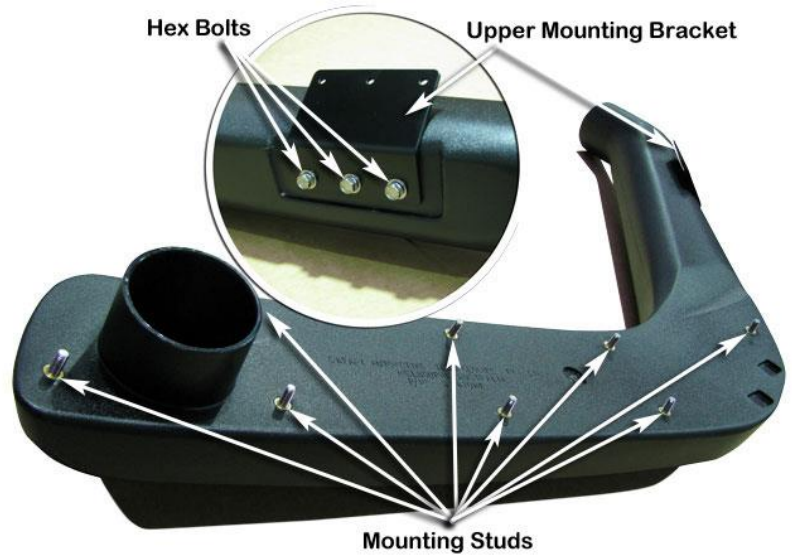

9

Place a strip of masking tape along the A-pillar trim.

Carefully install the snorkel body (Item 1) to the guard panel.

With the snorkel body correctly positioned, mark the three upper mounting bracket hole positions onto the masking tape as shown.

N.B: The mounting holes should be approx. 40 – 45mm from the edge of the 'A' pillar trim to the centre of the mounting holes as shown.

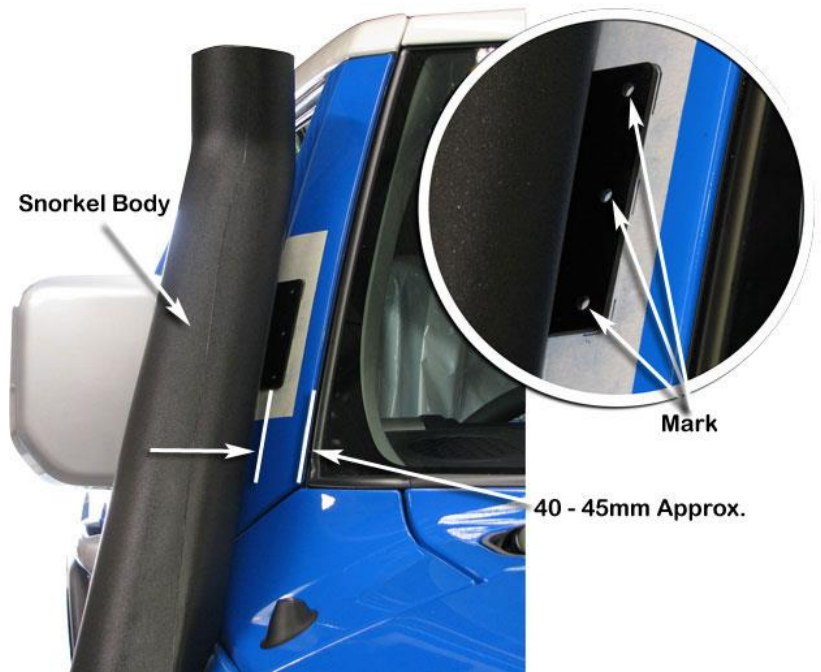

10

Remove the snorkel body (Item 1) from the vehicle and remove the upper mounting bracket (Item 3) from the snorkel body.

Drill a pilot hole at each of the three marked hole positions. Drill each hole position to 8mm diameter with a step drill or 8mm drill bit.

Deburr and paint holes to prevent rust.

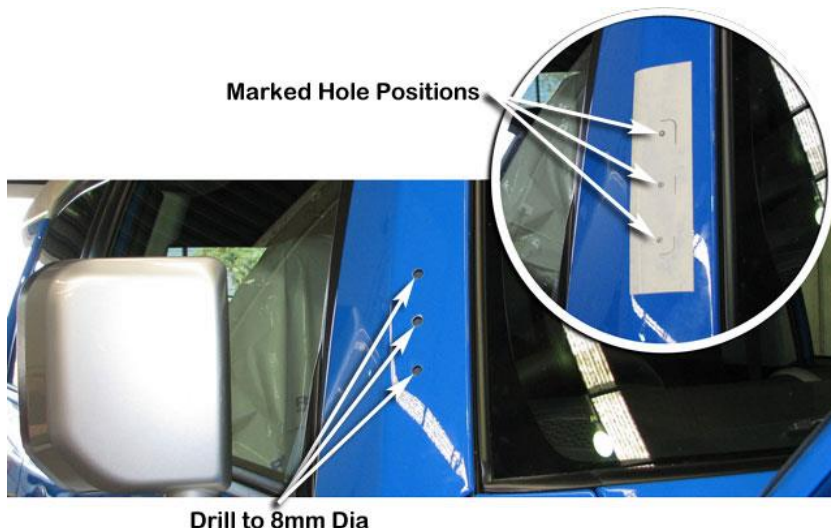

11

Install the plastic inserts (Item 6) into the upper mounting bracket holes in the A-pillar trim.

Secure the upper mounting bracket (Item 3) to the A-pillar trim with three stainless steel self tapping screws (Item 5).

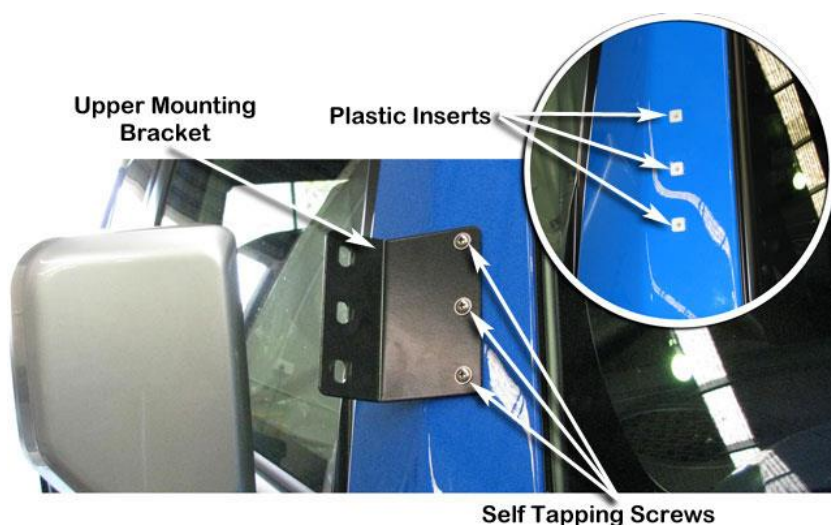

12

Carefully install the snorkel body (Item 1) to the guard panel and align the snorkel body to the guard panel and upper mounting bracket.

When correctly aligned, fasten the snorkel body to the guard panel with body washers (Item 8) and nyloc nuts (Item 9).

Fasten the snorkel body to the upper mounting bracket with hex bolts (Item 4).



Use a grinder or file to remove the two air cleaner inlet adaptor retaining tabs from the air cleaner base inlet snout.

Use a sharp blade or file to shorten the centre locating lug to approximately 10mm in length, the centre lug should be the same length as the two shorter lugs.

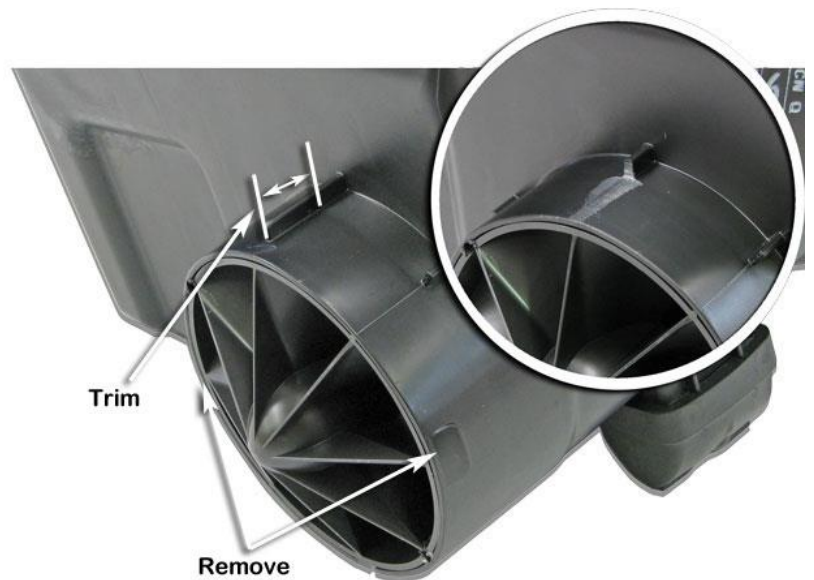

### INSTALLER OPTION

The air cleaner housing base contains a drain valve, a drain hole and a hole at the front as shown. These can permit water to enter the air intake.

It is up to the installer to decide whether the drain valve, drain hole and front hole should be sealed.



Loosely install the 90/110mm hose clamp (Item 11) over the snorkel body outlet.

Install the air entry hose (Item 10) through the hole in the inner guard panel and onto the snorkel body outlet.

Position the hose clamp onto the air entry hose. Do not tighten the hose clamp.



- 16** Install the 100/120mm hose clamp (Item 12) loosely over the outlet end of the air entry hose (Item 10).

Install the air cleaner base into position whilst guiding the air cleaner base inlet snout into the air entry hose (Item 10).

Secure the air cleaner base with the original mounting hardware.

Align the moulded part line of the air entry hose (Item 10) to the centre lug of the air cleaner base inlet, with the air entry hose aligned correctly, tighten the hose clamps (Items 11 & 12) at each end of the air entry hose.

Install the air cleaner element, air cleaner lid and any wiring plugs or components removed during the installation process.

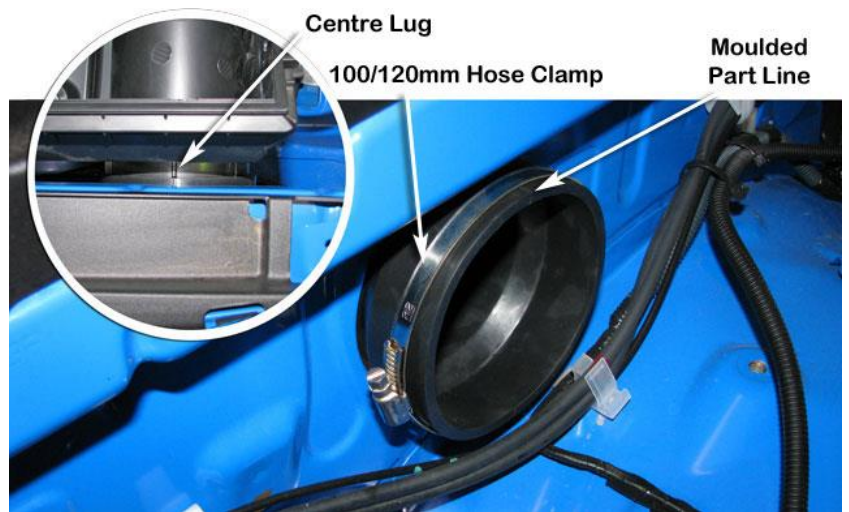

**17**

Install the black hose clamp (Item 17) loosely over the base of the air ram assembly (Item 2).

Install the air ram assembly onto the snorkel body.

Align the air ram assembly and tighten the black hose clamp (Item 17).



- 18** Install the guard mounted indicator (Aust Spec), guard liner, mud flap and any other items that may have been removed during the snorkel installation process.

- 19 N.B:** It is the installer's responsibility to ensure that all connections are water tight.