

# FITTING INSTRUCTIONS

## BP5190007L & BP5190007R

### TOYOTA HILUX 2015 ON FRONT

### WARNING

- ◆ This product must be installed exactly as per these instructions using only the hardware supplied.
- ◆ In the event of damage to any suspension component, contact your nearest authorised ARB stockist. Repairs or modifications to the suspension system components must not be attempted.
- ◆ Do not use this product for any vehicle make or model, other than those specified by ARB.
- ◆ Do not remove labels from suspension components.
- ◆ This product or its fixing must not be modified in any way.
- ◆ The installation of this product may require the use of specialized tools and/or techniques
- ◆ It is recommended that this product is only installed by trained personnel
- ◆ These instructions are correct as at the publication date. ARB Corporation Ltd. cannot be held responsible for the impact of any changes subsequently made by the vehicle manufacturer
- ◆ During installation, it is the duty of the installer to check correct operation/clearances of all components
- ◆ Work safely at all times

**Note:** These fitting instructions should be read in conjunction with the vehicle workshop manual.

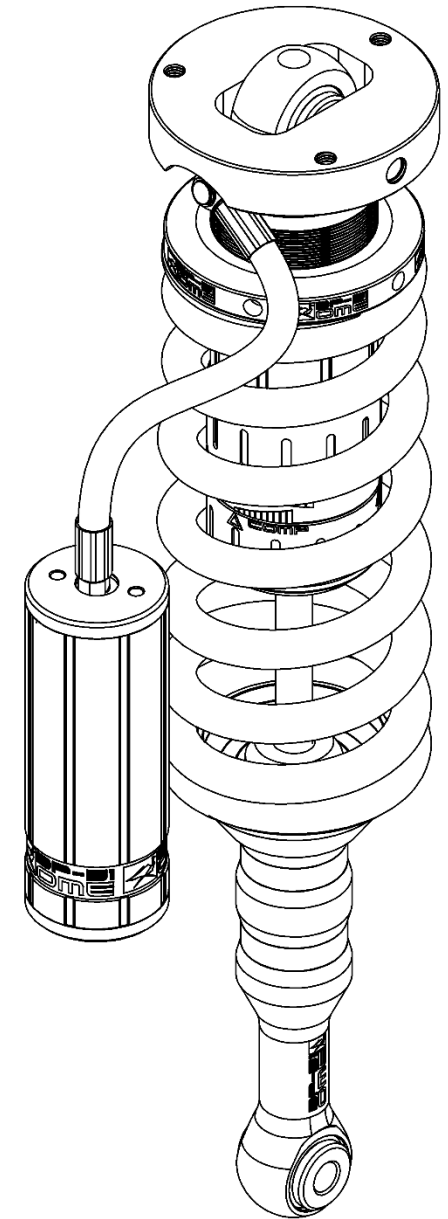

**FITTING KIT CONTENTS – VM80010018**

Item	Description	Qty	Part No.
1	RESERVOIR CLAMP	2	VE10010003
2	FRONT RESI BRACKET RIGHT (SHOWN)	1	VE10020020R
2	FRONT RESI BRACKET LEFT	1	VE10020020L
3	HILUX BRACING MOUNT	2	VG60050018
4	ADJUSTER TOOL	1	VC10010071
5	2015 HILUX FASTENER KIT	1	VM60010008
5.1	M10 X 1.5 X 20MM BOLT KIT	6	6151555
5.2	M6 X 16MM BOLT	4	VD60030003
5.3	M6 WASHER	5	VE70020005
5.4	M6 NYLOCK NUT	4	VD60010003
5.5	M10 X 1.5 X 30MM BOLT	4	6151232
5.6	M10 FLAT WAHSER	4	VE70020003
5.7	M10 NYLOCK NUT	4	VD60010005
5.8	M10 X 30 X 5MM SPACER WAHER	2	4584296

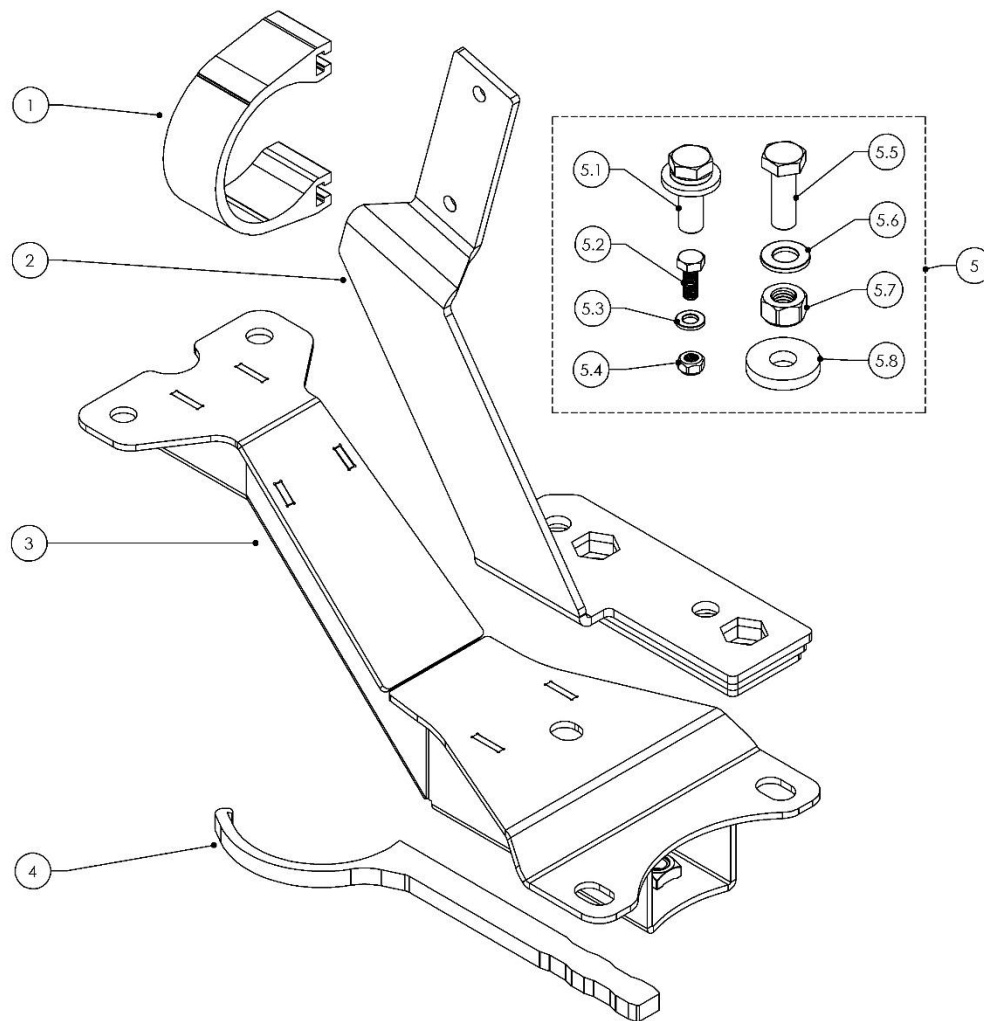

## DAMPER PREPARATION

Before fitment the spring preload may need to be adjusted to suit your front accessory fitment and desired ride height.

**Use workshop tool kit VM80020001 to aid spring adjustment.**

The preload is set at the factory to 20mm as shown by the diagram. This aims to achieve around 40mm increase in ride height over OE when a Bull Bar and winch are fitted.

It is required to set the preload before the strut assembly is fitted to the vehicle. Use a spring compressor to compress the spring, loosen the pinch bolt on the preload ring and adjust to the desired setting. Tighten the pinch bolt and remove the strut assembly from the spring compressor.

As a guide, set the preload as specified below to achieve around 40mm increase in ride height.

<u>Front accessories</u>	<u>Preload</u>	
	<b>Diesel</b>	<b>Petrol</b>
Bar & winch	20 mm	15 mm
Bar only	15 mm	10 mm
No accessories	10 mm	5 mm

**Spring preload must only be adjusted when a spring compressor is used to take load off the preload ring.**

**DO NOT** attempt to adjust preload with load on the spring when fitted to the vehicle.

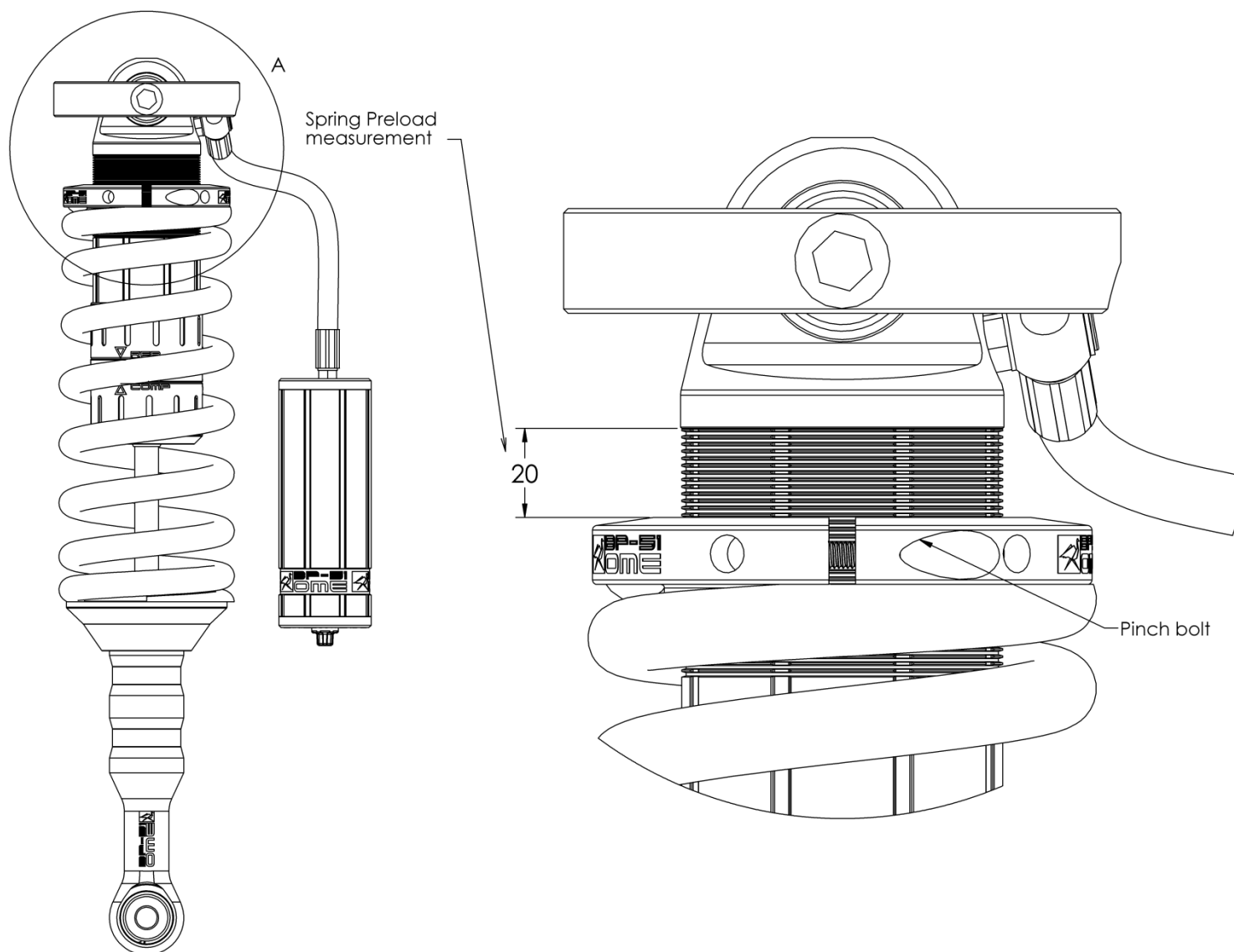

## FRONT CHASSIS BRACE MOUNTING SEQUENCE

**NOTE:** Before installing the front dampers both of the new front chassis braces must be installed.

Remove the front under body protection panel and retain all fasteners.

Remove both existing front chassis braces and disregard (1). Retain all fasteners.

Mount the new front chassis brace using the retained original fasteners (2). Torque original fasteners to 40 N.m (30 ft.lb).

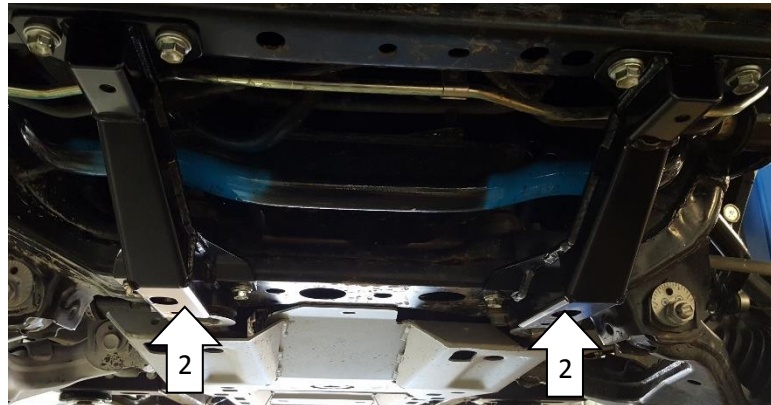
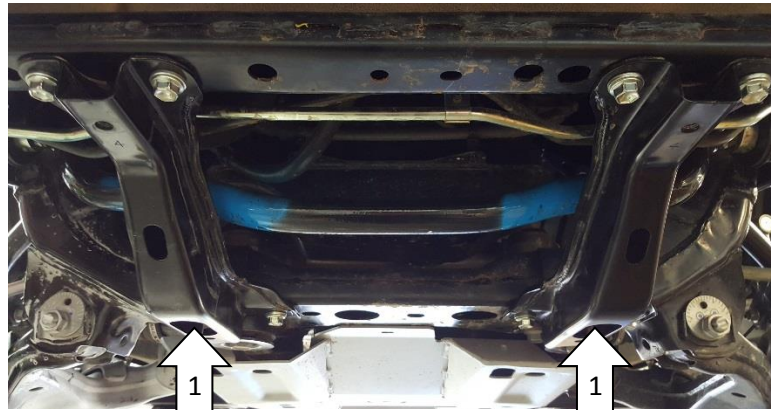



## DAMPER MOUNTING SEQUENCE

Remove old dampers from vehicle.

For LH and RH detach sway bar link from spindle (1) and ball joint from steering arm (2) and remove sway bar saddles (3). Retain original fasteners.

To provide good access for inserting the new strut assembly it helps to cable tie the sway bar to the upper arm (4).

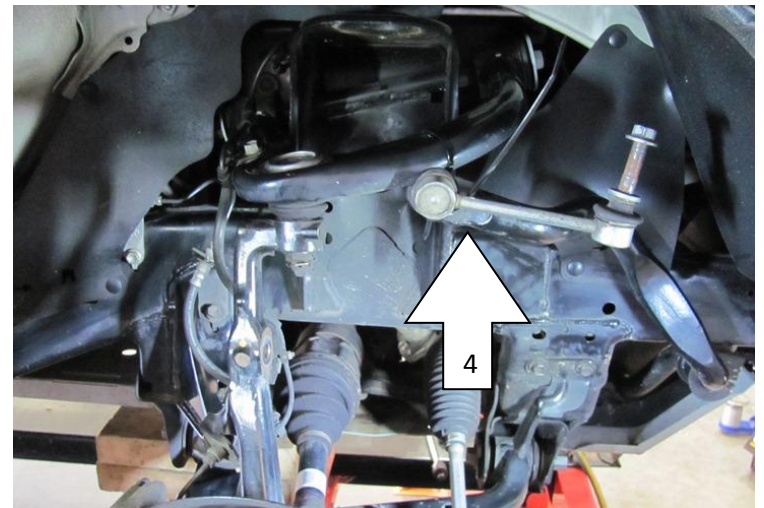
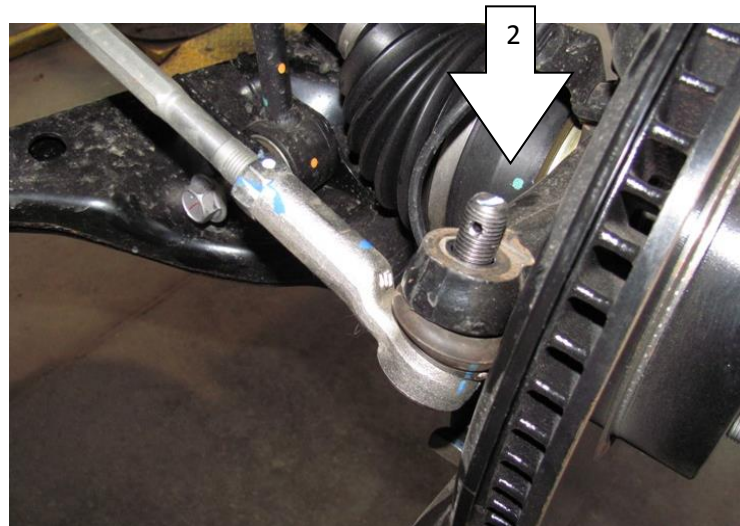
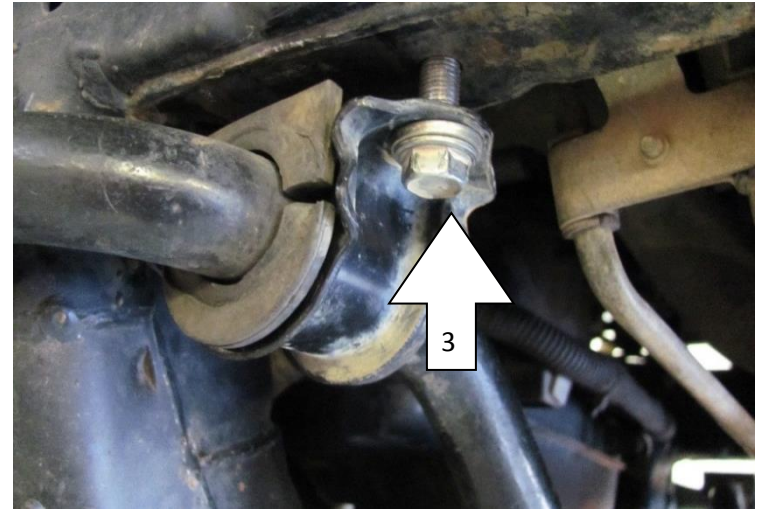
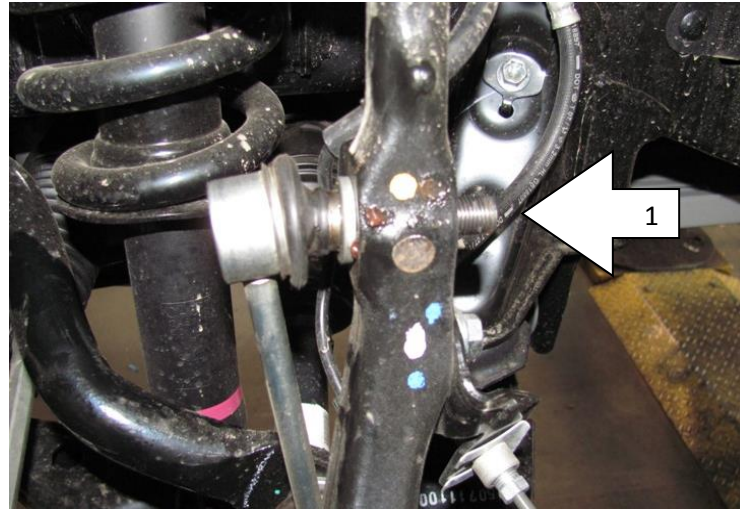

## DAMPER MOUNTING SEQUENCE

Left and Right Hand sides are the same with the exception of the way the hose exits the damper. L and R should be etched on the damper part number. When mounted in the vehicle the hose and reservoir should be towards the front.

Fit the damper and secure the top mount with M10 x 30 SEMS bolt assemblies (6151555) finger tight (1).

Secure the bottom eyelet mount using original bolt and nut. (2).

Fasten the top three bolts and bottom bolt securely.

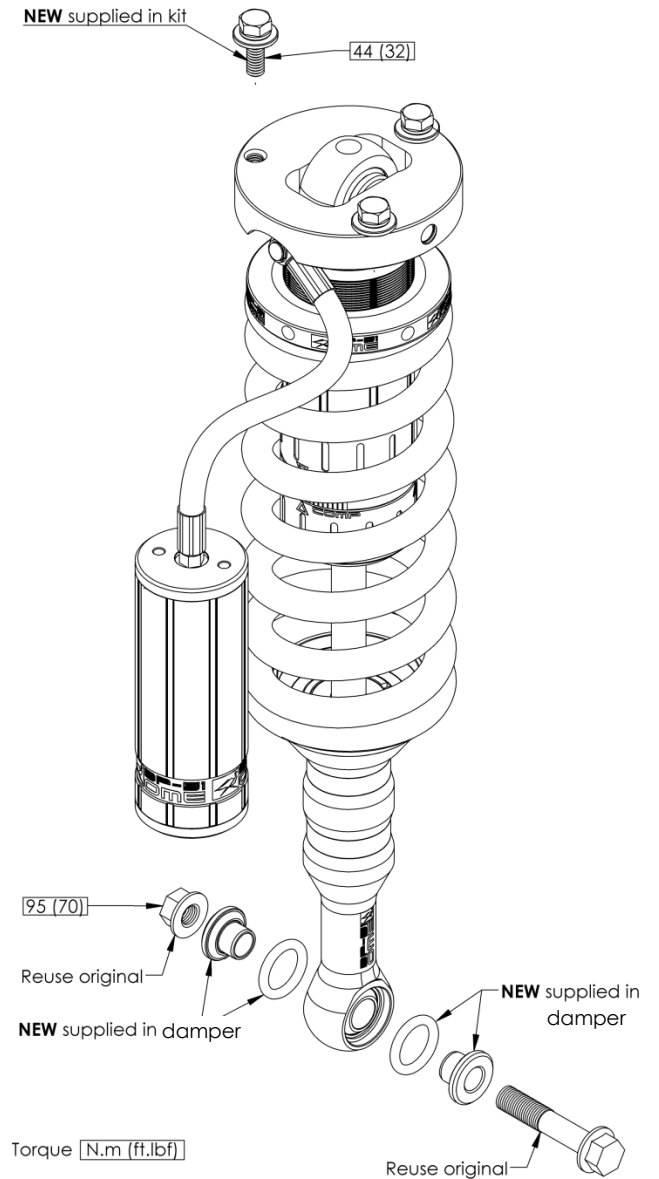



## RESERVOIR MOUNTING SEQUENCE

Fit M6 bolts to the Reservoir Bracket and secure with nyloc nut and flat washer (1).

The nuts and washers should be to the inside with the bolt hexagonal head to the outside to accept the reservoir mounting saddle.

Secure finger tight only at this stage.

Slide the saddle over the heads of the bolts in the mounting plate and then slide the reservoir through the saddle (2). Centralise the saddle on the plate and adjust the position of the reservoir as shown (3).

Tighten the M6 fasteners so that the reservoir is firmly held but can still be repositioned within the saddle.

Repeat for LHS.

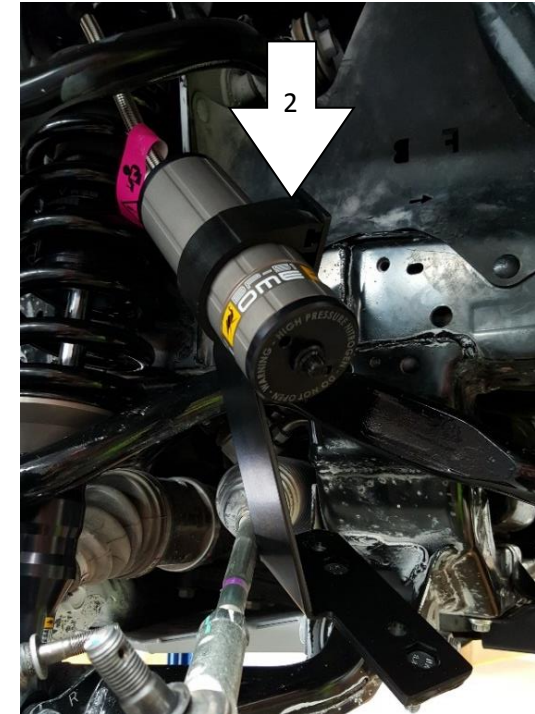
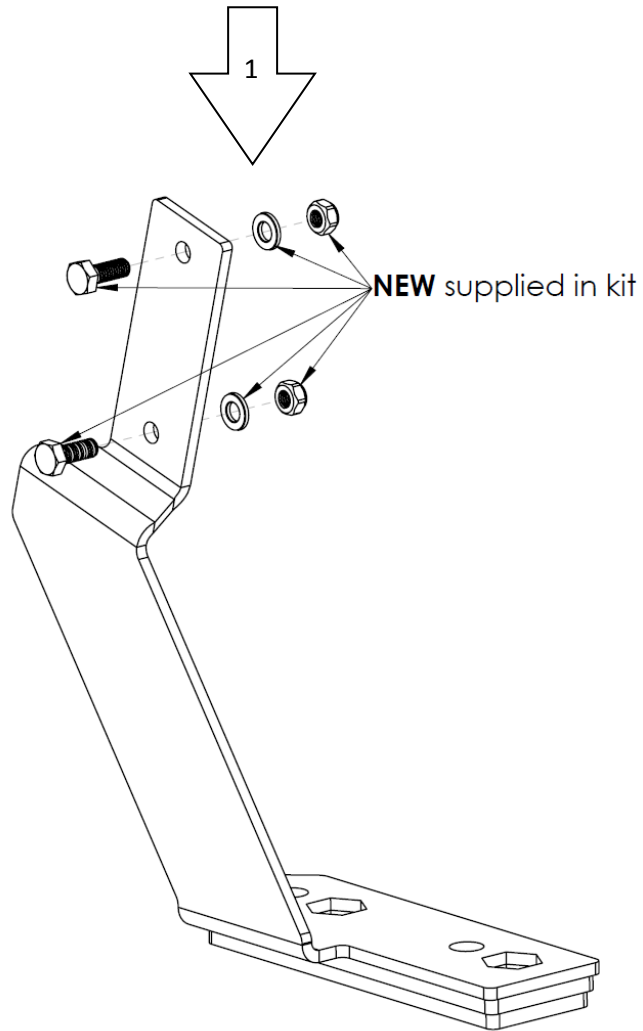

## SWAY BAR MOUNTING SEQUENCE

Before fitting the reservoir mounting bracket to the chassis, fit M10 x 30 fasteners (6151232) in the hexagonal shaped cavities as shown (1).

Remove the sway bar mount and rubber D bush.

Fit the reservoir mounting bracket to the sway bar mounting holes in the chassis using the original fasteners (2).

Fasten the sway bar saddle onto the new M10 fasteners that protrude out from the reservoir mounting bracket and secure using the new 10mm washers and M10 nyloc nuts supplied (3).

Repeat for LHS.

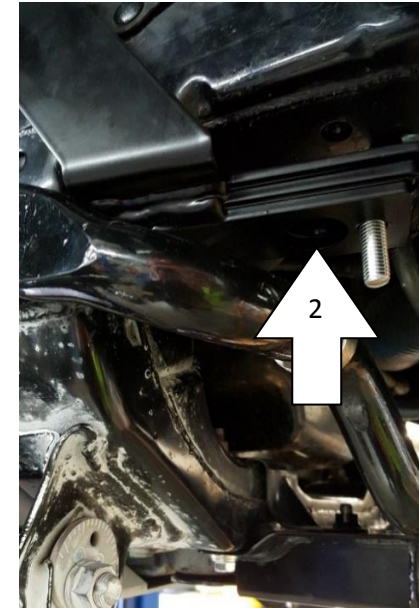
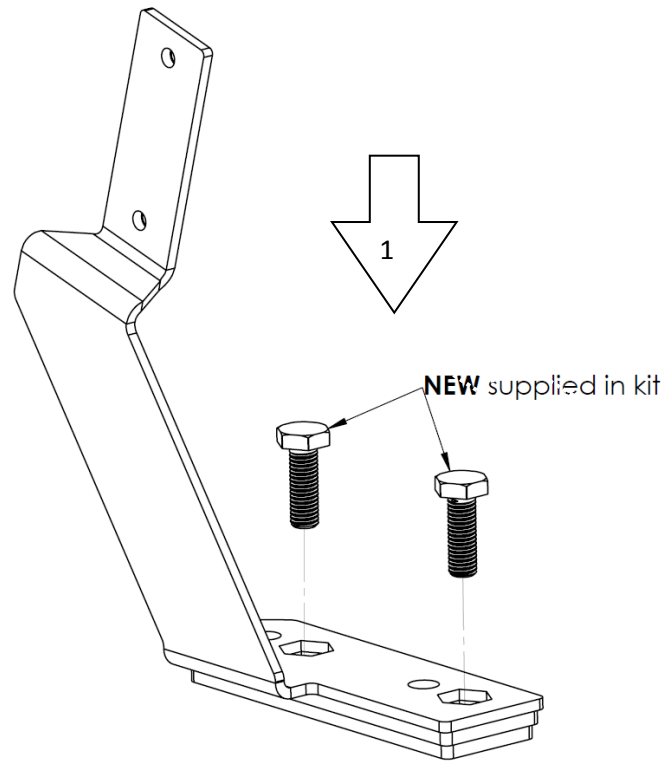



## FINAL STEPS

Now that all parts are fitted, ensure the reservoir hose is free of contact from any surfaces, rotate the reservoir within the saddle if necessary. Finally tighten the reservoir saddle M6 fasteners.

Check all fasteners are tightened securely as per the table below.

Re-attach the front under body protection panel using the retained original fasteners. If using ARB under body protection add the 5mm thick washer provided between the front mounting section of the chassis brace and under body protection panel (1).

The pink flag can be removed from the hose.

Fastener	Torque N.m (ft.lb)
Front brace to chassis	40 (30)
Sway bar link to upright	70 (52)
Steering tie rod end to upright	88 (65)
Reservoir bracket to chassis	40 (30)
Sway bar mount to reservoir bracket	40 (30)
Strut top hat	44 (32)
Strut to lower control arm	95 (70)

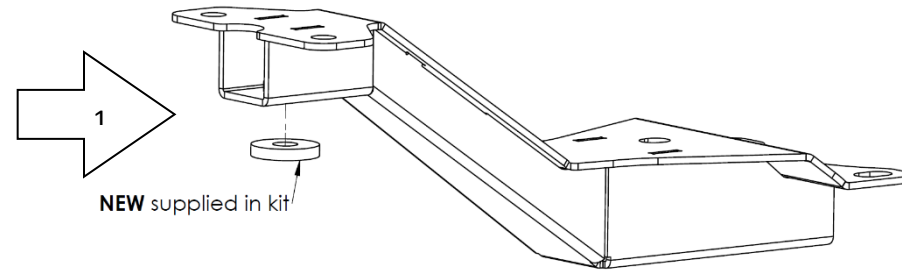

## DAMPING ADJUSTMENT

These dampers have been set in the factory to be used for a vehicle with Bull Bar and Winch fitted.

If your accessory fitment differs, use the table below as a guide for recommended Compression and Rebound adjuster settings.

Refer to the Owner's Manual for more information.

Front Accessories	Compression	Rebound
Factory setting	4	6
Bar & winch	4-8	6-10
Bar only	2-6	5-9
No accessories	0-4	4-8

## SPECIFICATIONS

- 1 Extended Length 540 mm
- 2 Compressed Length 439 mm

## SPARE PARTS

Refer to Service and Parts Manual, section: **BP-51 S&P 3.1-BP5190007**

