

FITTING INSTRUCTIONS

BP5190002L & BP5190002R

TOYOTA PRADO 120 FRONT

WARNING

- ◆ This product must be installed exactly as per these instructions using only the hardware supplied.
- ◆ In the event of damage to any suspension component, contact your nearest authorised ARB stockist. Repairs or modifications to the suspension system components must not be attempted.
- ◆ Do not use this product for any vehicle make or model, other than those specified by ARB.
- ◆ Do not remove labels from suspension components.
- ◆ This product or its fixing must not be modified in any way.
- ◆ The installation of this product may require the use of specialized tools and/or techniques
- ◆ It is recommended that this product is only installed by trained personnel
- ◆ These instructions are correct as at the publication date. ARB Corporation Ltd. cannot be held responsible for the impact of any changes subsequently made by the vehicle manufacturer
- ◆ During installation, it is the duty of the installer to check correct operation/clearances of all components
- ◆ Work safely at all times

Note: These fitting instructions should be read in conjunction with the vehicle workshop manual.

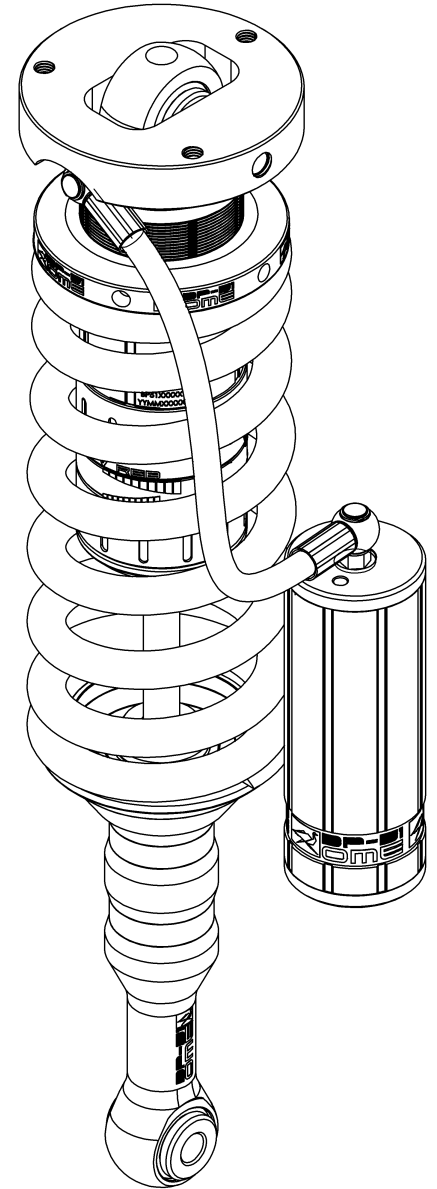

FITTING KIT CONTENTS – VM80010029

Item	Description	Qty.	Part No.
1	RESERVOIR CLAMP	2	VE10010003
2	PRADO RESI BRACKET FRONT RIGHT	1	VE10020010R
3	PRADO RESI BRACKET FRONT LEFT	1	VE10020010L
4	SWAY BAR RELOCATION MOUNT	1	VF60060001
5	ADJUSTER TOOL	1	VC10010071
6	PRADO/FJ FASTENER KIT FRONT	1	VM60010004
6.1	M10 X 1.5 X 20MM BOLT KIT	6	6151555
6.2	M10 X 1.5 X 20MM BOLT	4	VD60030005
6.3	M10 SPING WASHER	4	4581292
6.4	M10 FLAT WASHER	4	VE70020003
6.5	M8 X 1.25 X 25MM BOLT	2	6151546
6.6	M8 SPRING WASHER	2	4581047
6.7	M8 WASHER	2	VE70020004
6.8	M8 CAGED NUT BRACKET	1	VE10040002
6.9	M8 CAGED NUT	2	6151303
6.10	M6 X 30MM BOLT	2	6151228
6.11	M6 SPRING WASHER	2	1581287
6.12	M6 CAGED NUT BRACKET	2	VE10040001
6.13	M6 CAGED NUT	2	6151315
6.14	M6 X 16MM BOLT	4	VD60030003
6.15	M6 WASHER	4	VE70020005
6.16	M6 NYLOCK NUT	4	VD60010003

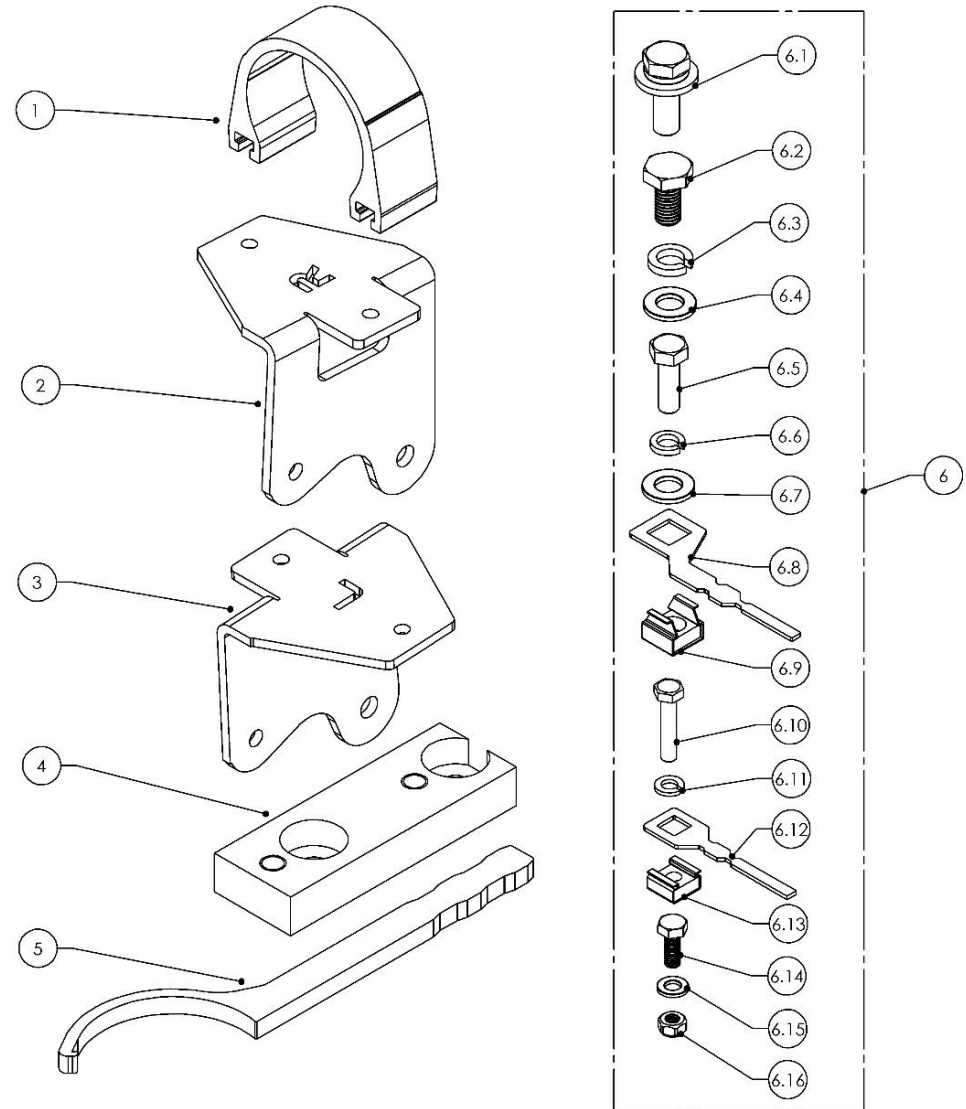

DAMPER PREPARATION

Before fitment the spring preload may need to be adjusted to suit your front accessory fitment and desired ride height.

Use workshop tool kit VM80020001 to aid spring adjustment.

The preload is set at the factory to 20mm as shown by the diagram. This aims to achieve 30-40mm increase in ride height over OE when a Bull Bar and winch are fitted.

It is required to set the preload before the strut assembly is fitted to the vehicle. Use a spring compressor to compress the spring, loosen the pinch bolt on the preload ring and adjust to the desired setting. Tighten the pinch bolt and remove the strut assembly from the spring compressor.

As a guide, set the preload as specified below to achieve 30-40mm increase in ride height.

Front accessories	Preload	
	Diesel	Petrol
Bar & winch	20 mm	15 mm
Bar only	15 mm	10 mm
No accessories	10 mm	5 mm

Spring preload must only be adjusted when a spring compressor is used to take load off the preload ring.

DO NOT attempt to adjust preload with load on the spring when fitted to the vehicle.

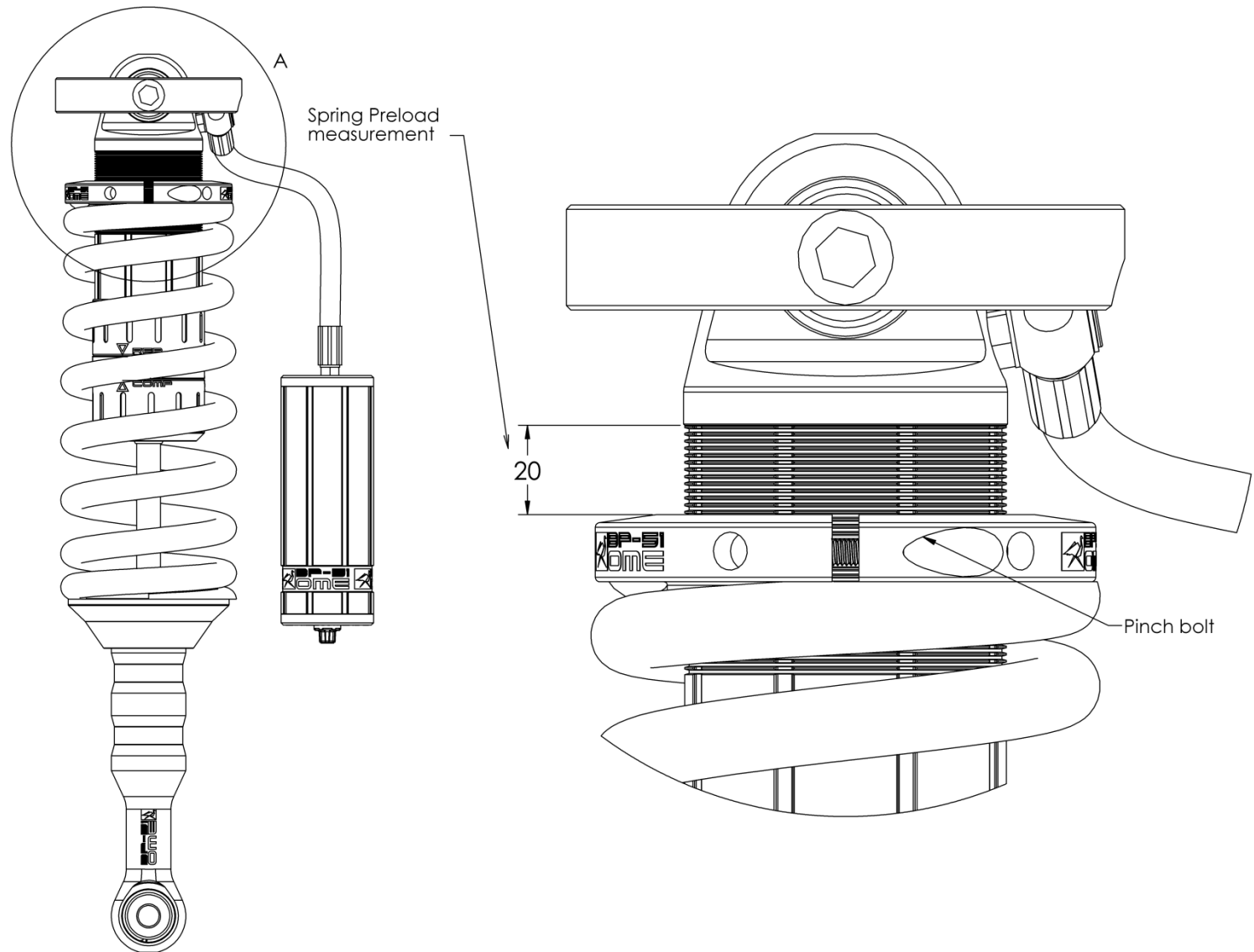

DAMPER MOUNTING SEQUENCE

Remove old dampers from vehicle.

For LH and RH detach sway bar link from spindle (1) and ball joint from steering arm (2) and remove sway bar saddles (3).

To provide good access for inserting the new strut assembly it helps to cable tie the sway bar to the upper arm (4).

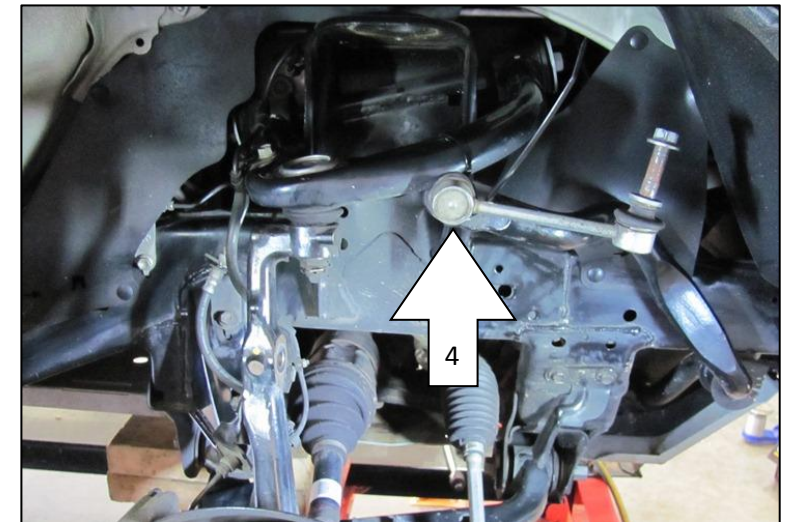
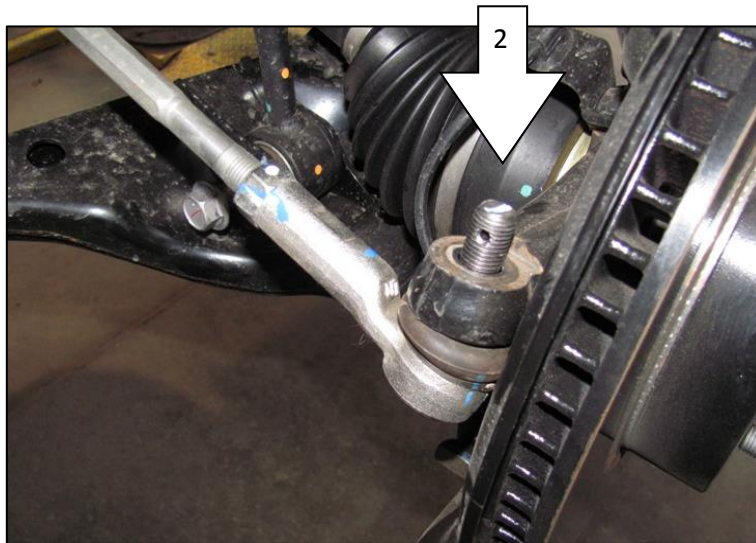
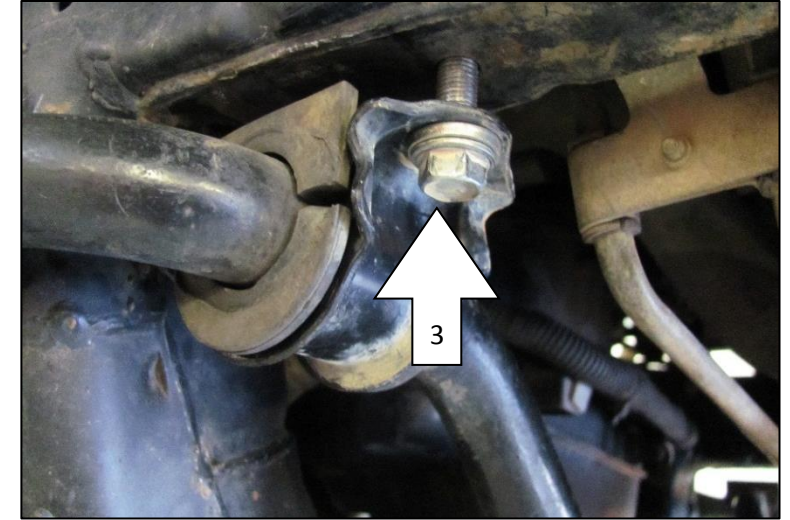
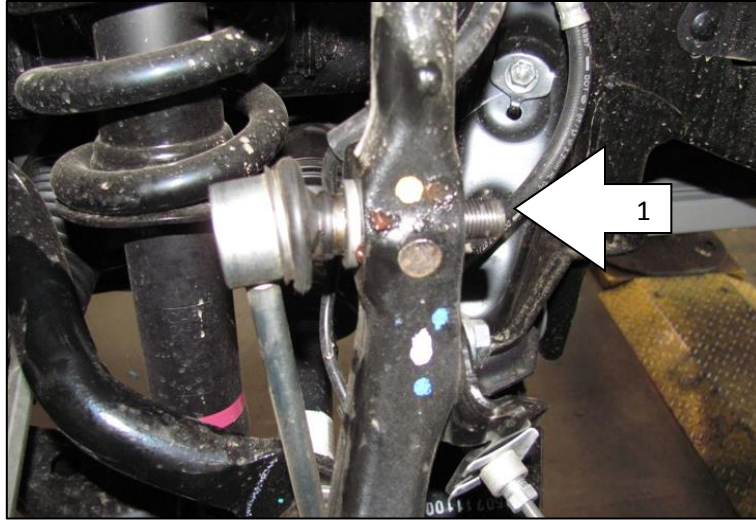

DAMPER MOUNTING SEQUENCE

Left and Right Hand sides are the same with the exception of the way the hose exits the damper. L and R should be etched on the damper part number. When mounted in the vehicle the hose and reservoir should be towards the front.

Fit the damper and secure the top mount with bolts and washers finger tight (1).

Secure bottom mount using original bolt and nut (2).

Fasten top three bolts and bottom bolt securely.

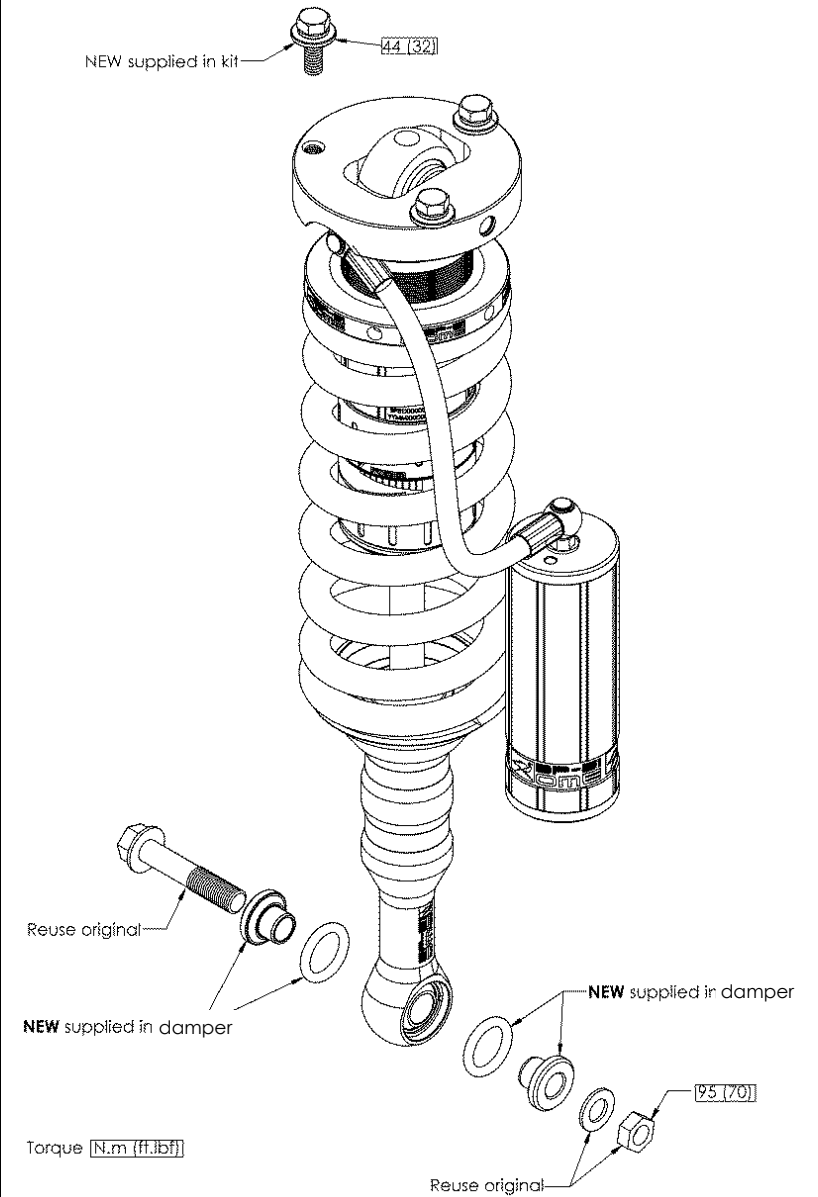

RESERVOIR MOUNTING SEQUENCE (RH SHOWN)

Fit M6 bolts to mounting bracket and secure with nyloc nut and flat washer (1).

Secure finger tight only at this stage.

Bend the new nut plates (2) by hand 90 degrees and assemble with 2 x M6 and 1 x M8 cage nuts.

Fit the reservoir mounting plate to the **outside of the chassis rail**. Insert plates through opening in chassis rail and secure with new M8 and M6 bolt, flat and spring washer (3). Insert plates through opening on chassis rail.

A threaded hole is present for new M8 bolt on LH chassis rail, no cage nut required.

When bolts are secured, break the tabs away from the nut plate (4).

Fit the mounting saddle to the reservoir and slide over the heads of the bolts in the mounting plate. Centralise the saddle on the plate and adjust the position of the reservoir as shown (5).

Reservoir should not make contact with any engine components or vehicle body. Securely fasten M6 nuts.

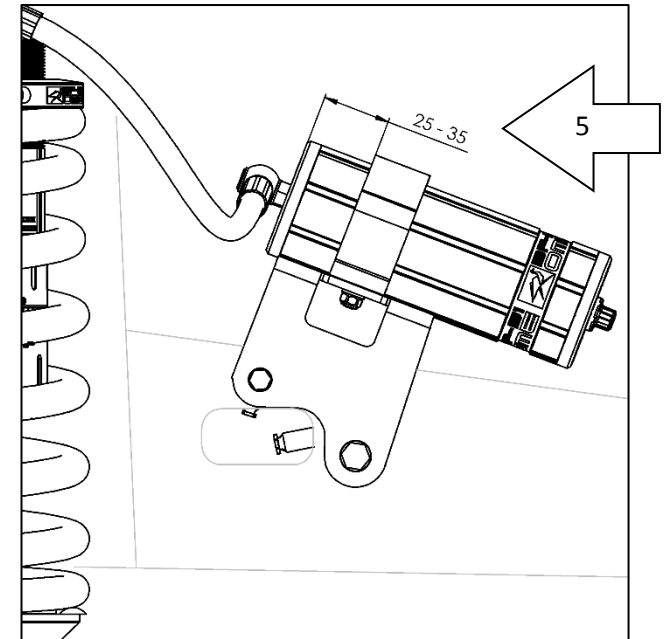
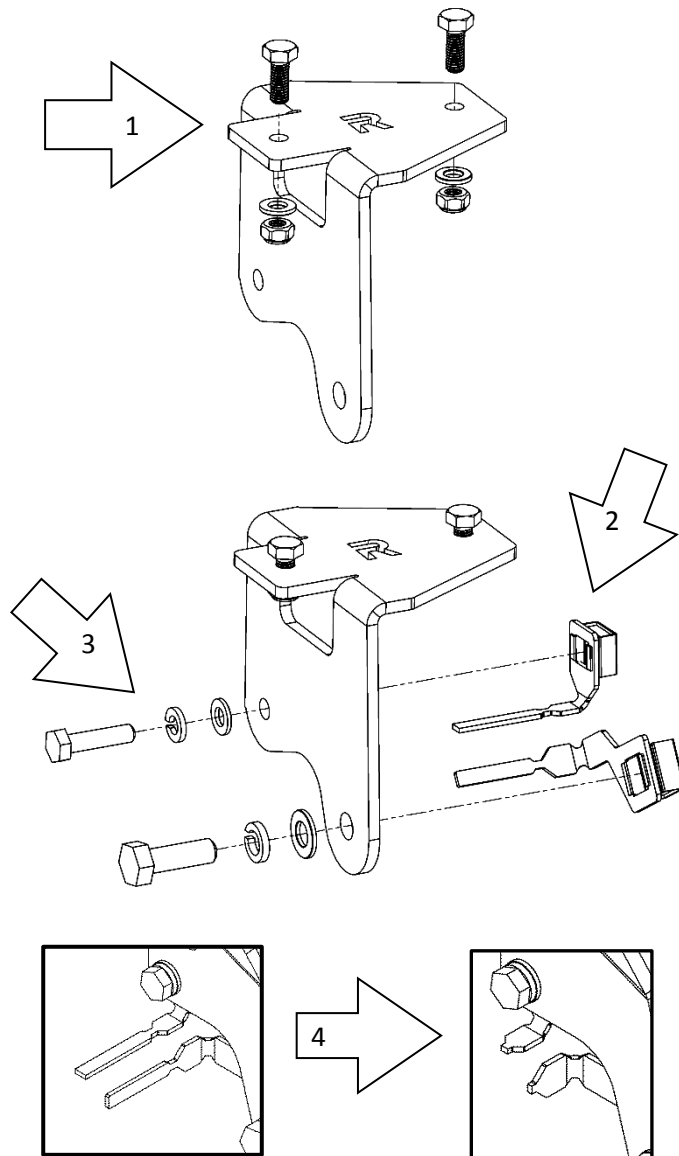

SWAY BAR SPACER FITMENT

The sway bar spacer is designed to move the sway bar forward and down to provide more clearance around the spring and spring seat.

Remove the sway bar saddle on both sides of the vehicle (1).

Fit new sway bar spacer block as shown and secure with the original bolts (2).

Fit the original sway bar saddle to the spacer block using the M10 x 20 bolts supplied and torque same as original bolts (3).

Check all fasteners are tightened securely as per table below.

Fastener	Torque N.m (ft.lb)
Sway bar link to upright	70 (52)
Steering tie rod end to upright	88 (65)
Sway bar spacer & brkt to chassis	40 (30)
Strut top hat	44 (32)
Strut to lower control arm	95 (70)

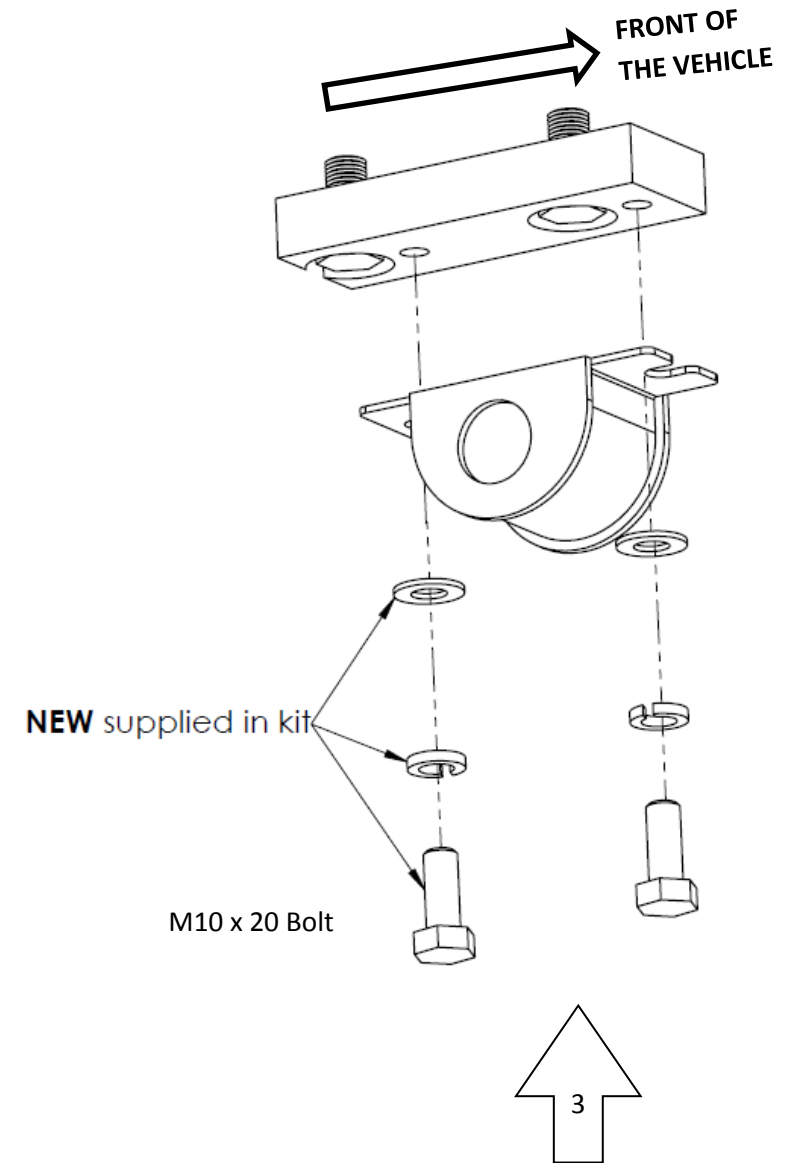
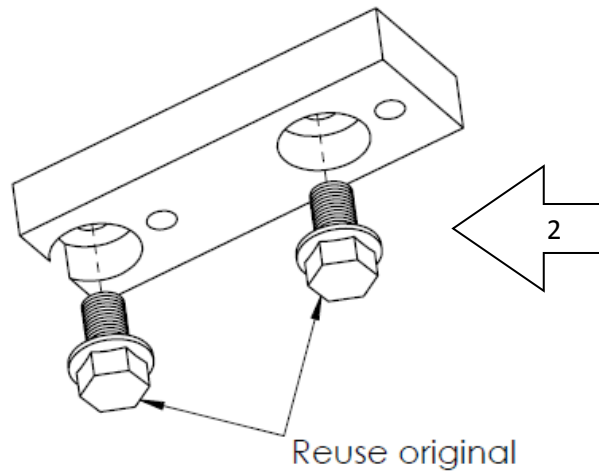
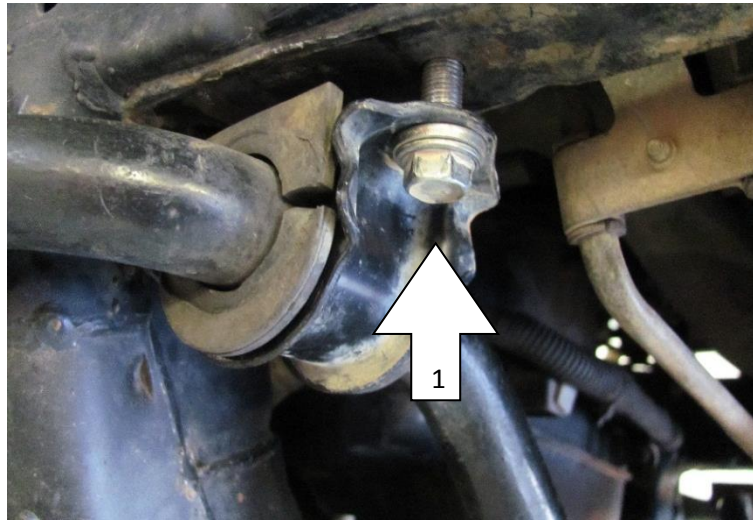

SPECIFICATIONS AND SPARE PARTS

DAMPING ADJUSTMENT

These dampers have been set in the factory to be used for a vehicle with Bull Bar and Winch fitted.

If your accessory fitment differs, use the table below as a guide for recommended Compression and Rebound adjuster settings.

Refer to the Owner's Manual for more information.

Front Accessories	Compression	Rebound
Factory setting	4	6
Bar & winch	4-8	6-10
Bar only	2-6	5-9
No accessories	0-4	4-8

SPECIFICATIONS

- 1 Extended Length 545 mm
- 2 Compressed Length 439 mm

SPARE PARTS

Refer to Service and Parts manual, section: **BP-51 S&P 3.1-BP5190002**

