

FITTING INSTRUCTIONS

BP5190015L & BP5190015R FORD RANGER 22.75MY FRONT

WARNING

- ◆ This product must be installed exactly as per these instructions using only the hardware supplied.
- ◆ In the event of damage to any suspension component, contact your nearest authorised ARB stockist. Repairs or modifications to the suspension system components must not be attempted.
- ◆ Do not use this product for any vehicle make or model, other than those specified by ARB.
- ◆ Do not remove labels from suspension components.
- ◆ This product or its fixing must not be modified in any way.
- ◆ The installation of this product may require the use of specialized tools and/or techniques
- ◆ It is recommended that this product is only installed by trained personnel
- ◆ These instructions are correct as at the publication date. ARB Corporation Ltd. cannot be held responsible for the impact of any changes subsequently made by the vehicle manufacturer
- ◆ During installation, it is the duty of the installer to check correct operation/clearances of all components
- ◆ Work safely at all times

Note: These fitting instructions should be read in conjunction with the vehicle workshop manual.

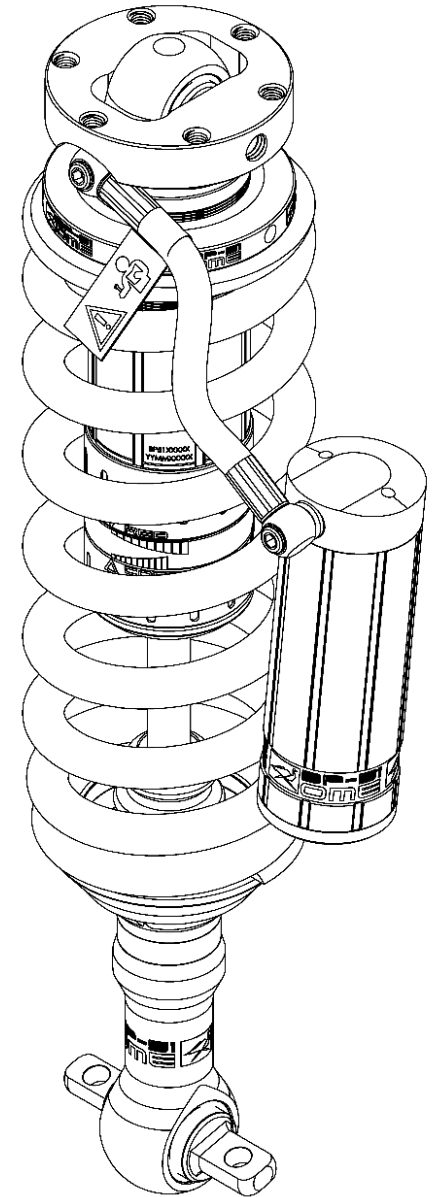

FITTING KIT CONTENTS – VM80010053

Item	Description	Qty.	Part No.
1	BRKT FORD RANGER FRONT	1	VE10020043
2	BRKT FORD RANGER FRONT	1	VE10020042
3	BP51 FASTENER KIT FORD P703 FRONT	1	VM60010043
3.1	M12 X 1.25 X 70 HX FL BOLT	4	6152022
3.2	NUT FL M12 X1.25	4	6152023
3.3	M10 X 1.5 X 30MM BOLT	6	6151555
3.4	M8 x 1.25 x 25 BOLT	6	6151546
3.5	M6 X 16MM BOLT	4	VD60030003
3.6	M8 FLAT WASHER	8	4581085
3.7	M6 SMALL WASHER	4	VE70020005
3.8	M8 NYLOC	2	6151212
3.9	M6 NYLOCK NUT	4	VD60010003
3.10	NUT U M8	4	6151294
4	ADJUSTER TOOL	1	VC10010071
5	RESERVOIR CLAMP	2	VE10010003
6	F/INST BP-51 RANGER FRONT	1	VM90010059
7	MANUAL: OWNERS MANUAL	1	VM90020001

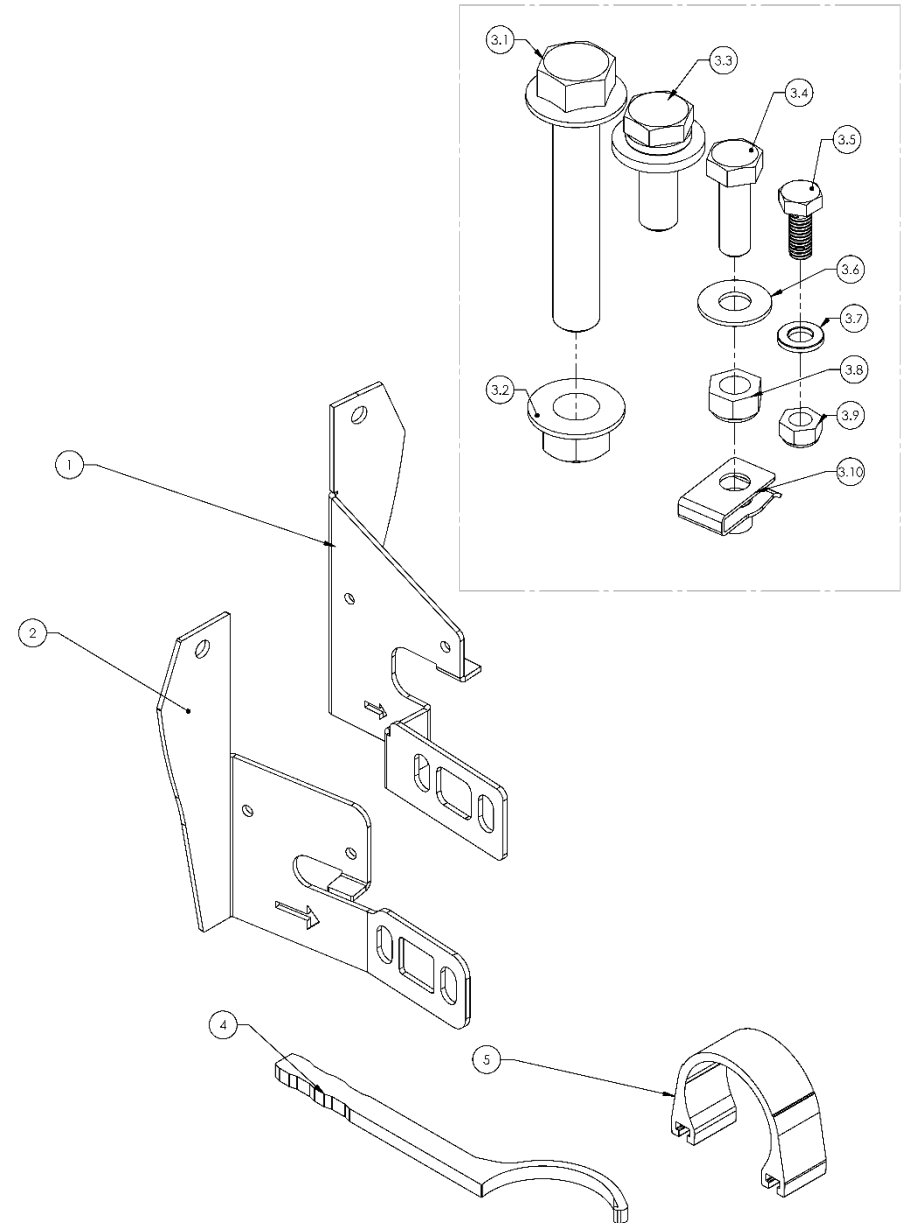

DAMPER PREPARATION

SPRING PRE-LOAD ADJUSTMENT

Before fitment, the spring preload may need to be adjusted to suit your front accessory fitment and desired ride height.

Use workshop tool kit VM80020001 to aid spring adjustment.
Refer to BP-51 Service and Parts Manual 1.2_Coilover Spring Adjustment for more detail.

The preload is set at the factory to 5mm as shown by the diagram. This aims to achieve around 45mm increase in ride height over OE when no accessories are fitted.

Preload must be set before the strut assembly is fitted to the vehicle. Use a spring compressor to compress the spring, loosen the pinch bolt (1) on the preload ring and adjust (2) to the desired setting (See table below).

Tighten the pinch bolt and remove the strut assembly from the spring compressor.

As a guide, set the preload as specified below to achieve around 50mm (2") increase in ride height.

Front Accessories	Preload (mm)
No accessories	5
Bar only	15
Bar & Winch	20
Bar, Winch, UVP +	25

Spring preload must only be adjusted when a spring compressor is used to take load off the preload ring.

DO NOT attempt to adjust preload with load on the spring when fitted to the vehicle.

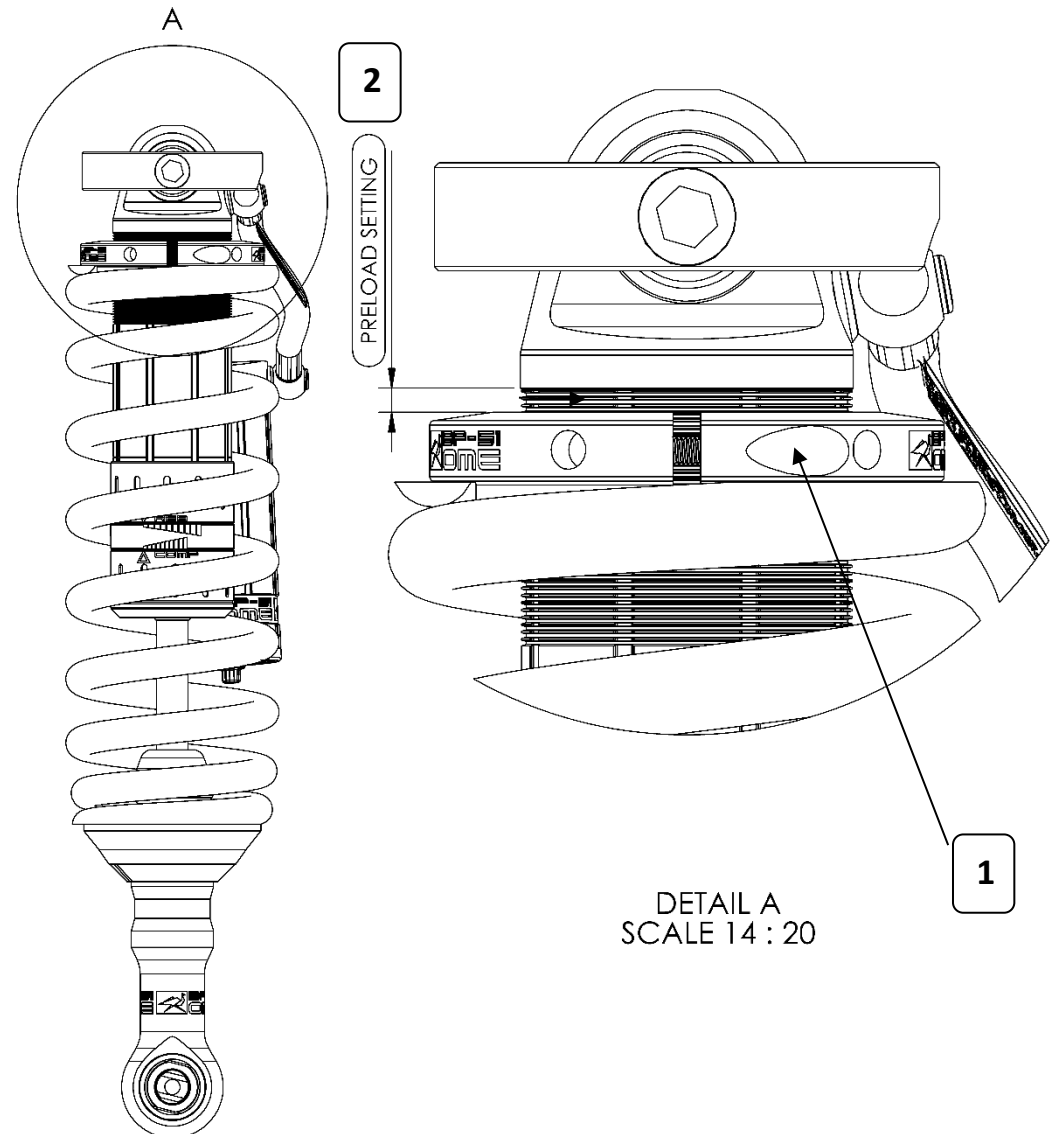

VEHICLE PREPARATION REMOVING STRUT

Use the following steps as a guide to remove strut. Ford P703 Ranger workshop manual may also be used where available to remove the strut.

1. Remove wheel.
2. Support the Lower Control Arm with a jack stand or similar.
3. Remove lower shock mounting nuts (X2).
4. Using a soft hammer (nylon), drive the studs out of the lower shock cross pin.
5. Detach tie rod from steering knuckle

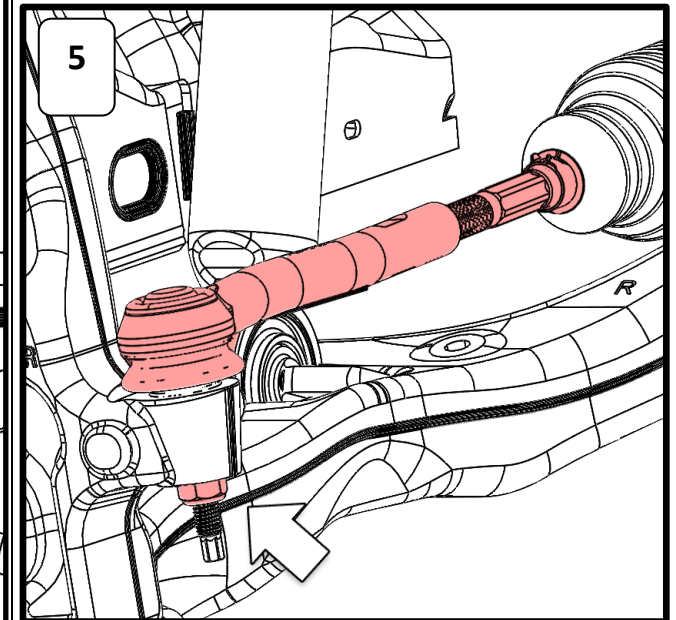
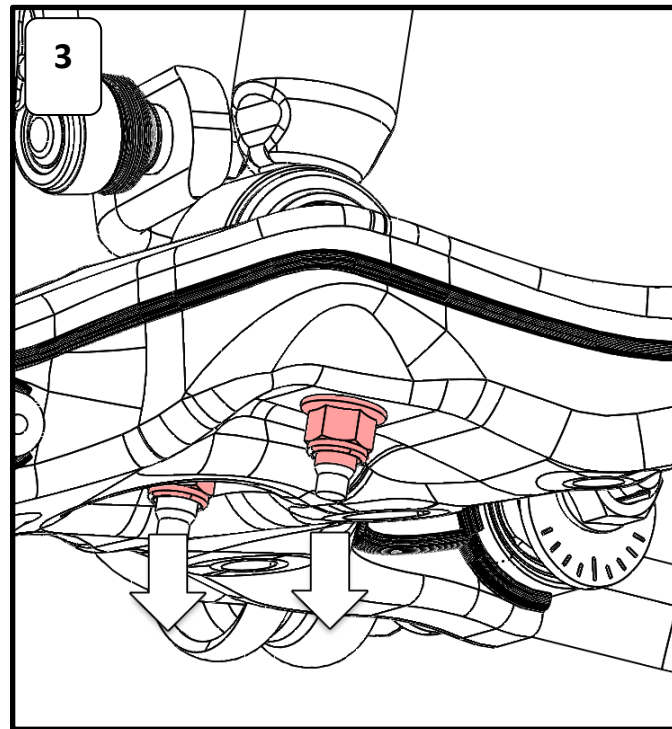
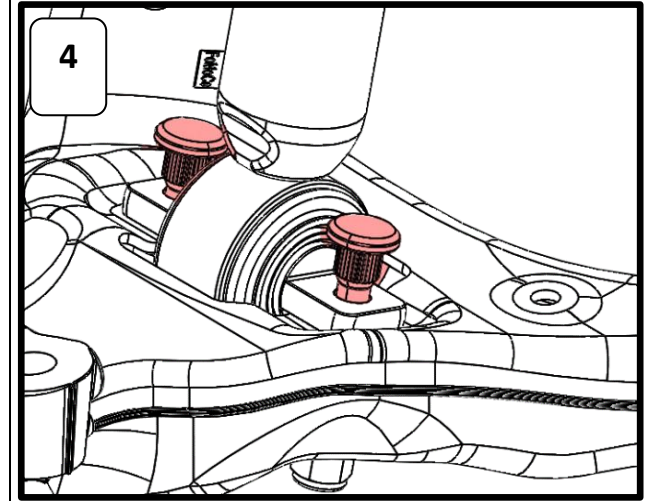
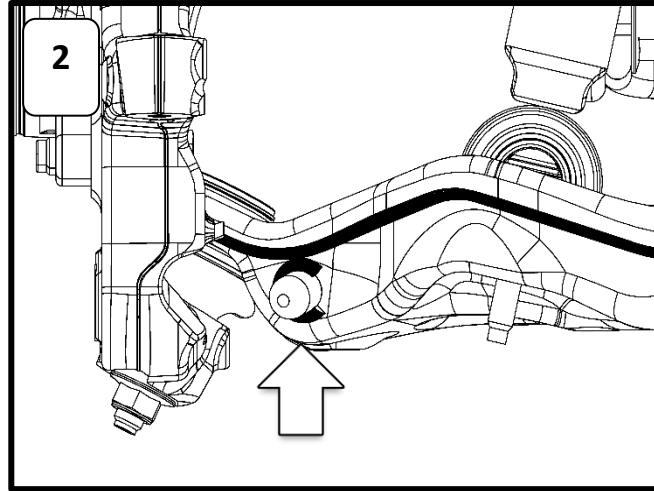

VEHICLE PREPARATION CONTINUED...

6. Detach the sway bar link from the steering knuckle
7. Detach the steering knuckle from the upper control arm (UCA) take care to prevent the driveshaft from dropping out.
8. Detach the steering rack ball joint from the upright.
9. Remove the strut top mount nuts and discard
10. Remove the shock absorber and discard

NOTE:

Take care to prevent the drive shaft from dropping out. Re-attach the upright to the upper control arm (refer to picture No.8) loosely until the BP-51 is ready to be installed.

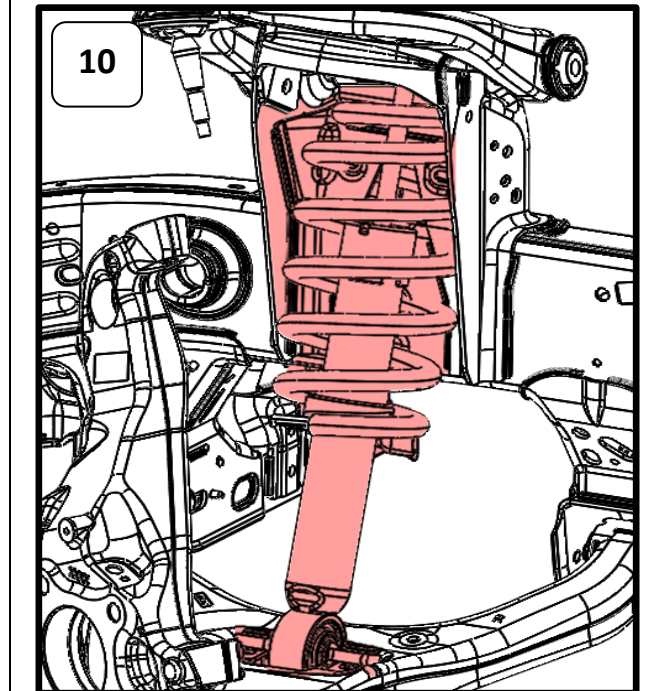
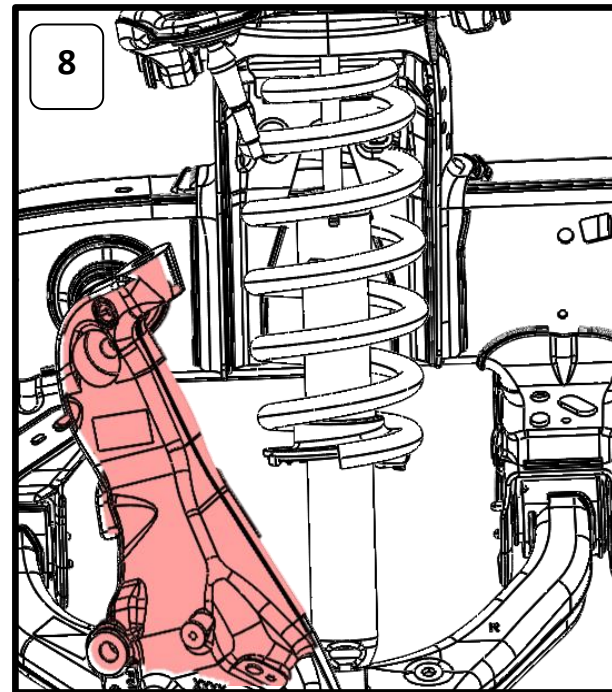
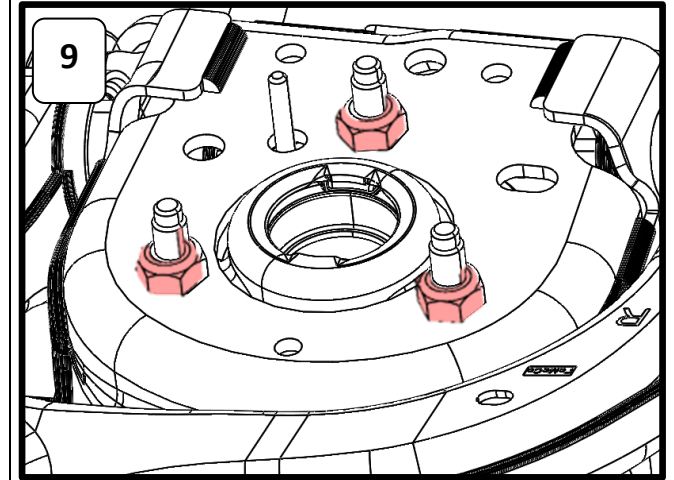
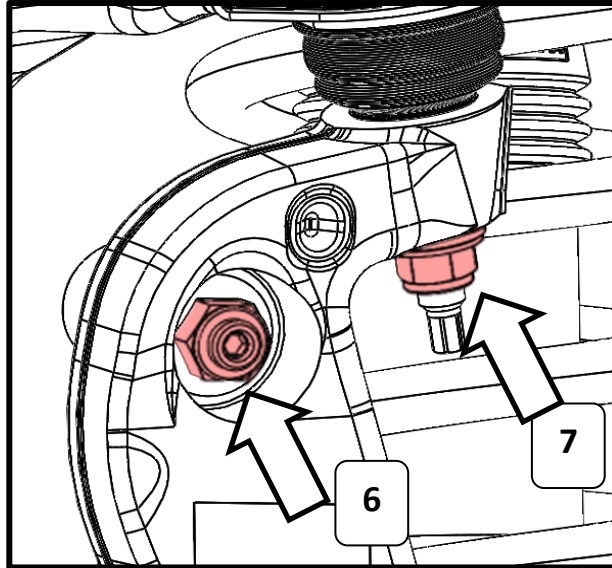

VEHICLE PREPARATION

WHEEL ARCH TRIM

Left hand side trim

1. Left Hand Side Trim does not require modification. The interfering rubber guard can be placed behind the reservoir mount

Right hand side trim

Right Hand Side Trim requires 45mm (minimum) removed from the wheel arch forward of the tower (see image 2).

2.
 - i. Remove plastic retaining clips
 - ii. Draw a line vertically on the right-hand side of the larger retaining clip
 - iii. Cut and discard the part to the left of the cut line
 - iv. Reinstall the two retaining clips to the right of the cut line



Do not cut LHS liner

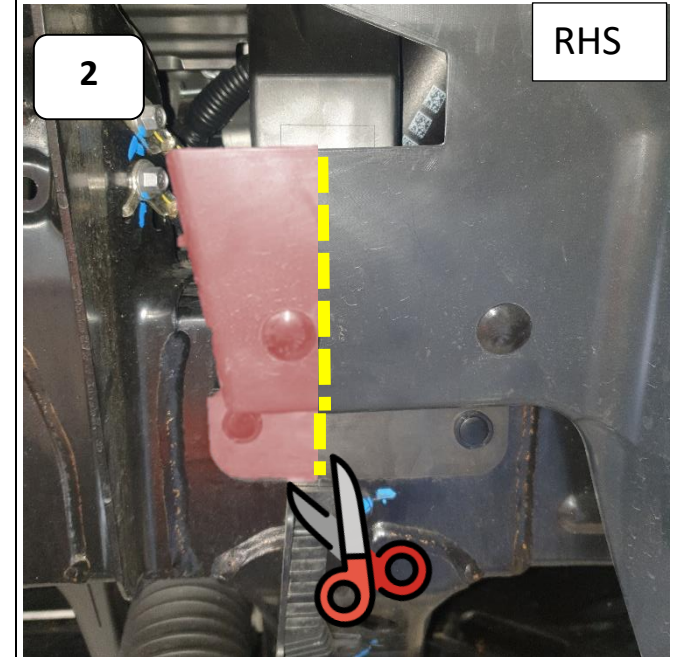

Excess liner removed for visual purposes

DAMPER ORIENTATION

BANJO FITTING FACING OUTWARDS

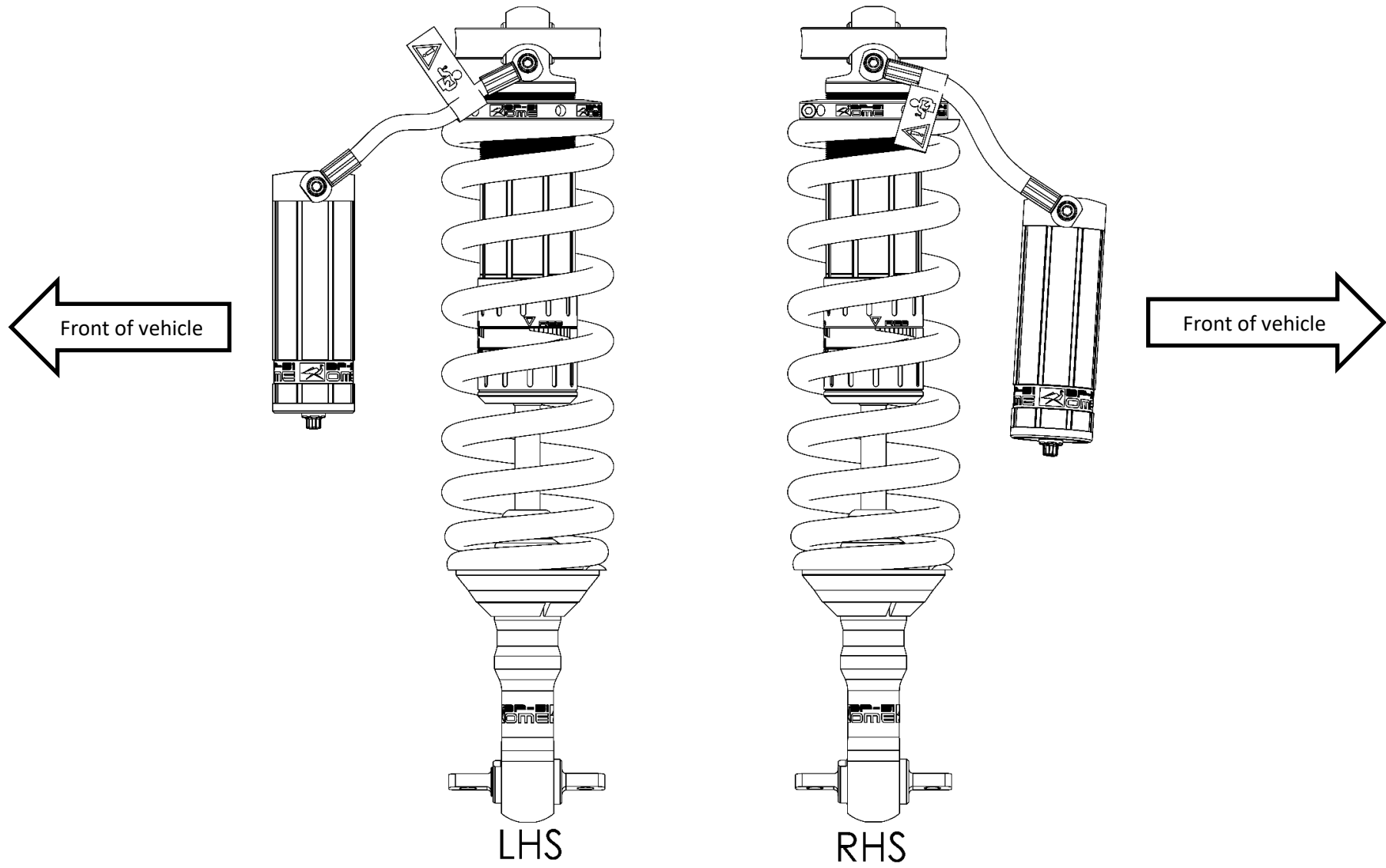

DAMPER MOUNTING SEQUENCE

BP5190015 L and BP5190015R are the same with the exception of the way the hose exits the damper. L and R is etched on the damper part number.

When mounted in the vehicle the hose and reservoir should be forward of the strut tower.

Reservoir Mount:

1. Pre assemble the reservoir bracket as shown
2. Insert U nuts into the chassis forward of the shock tower
3. Locate the holes forward shown in image (5) forward shock, (UCA not shown)
4. insert U nuts as shown

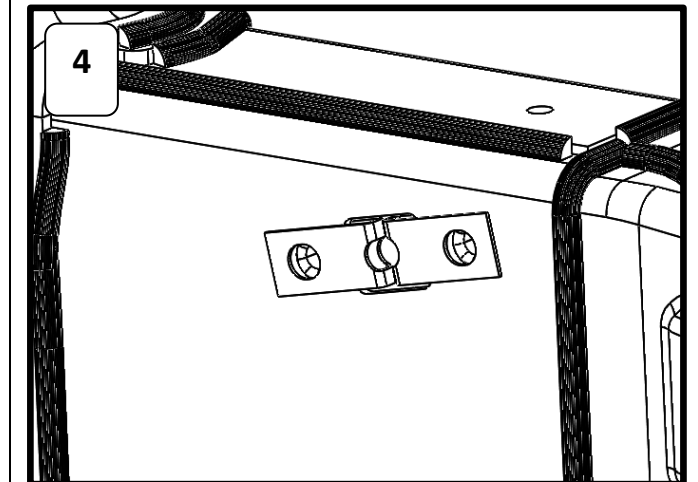
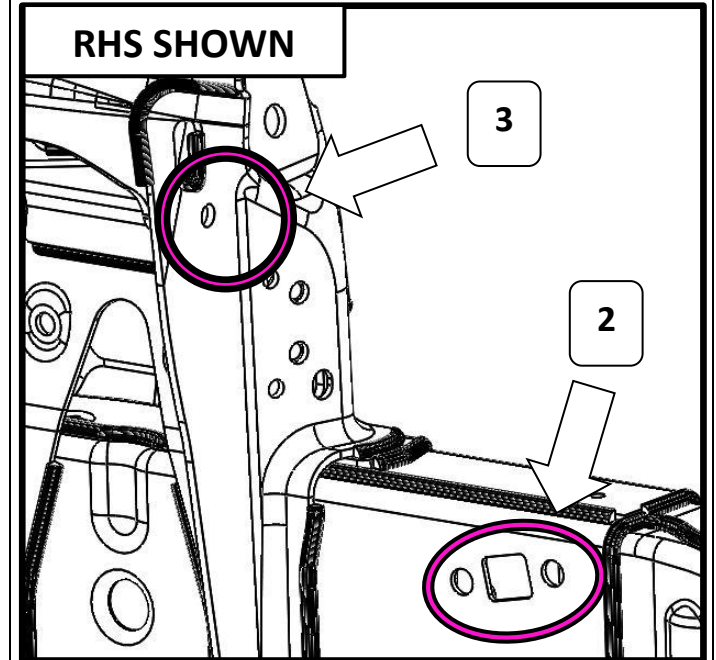
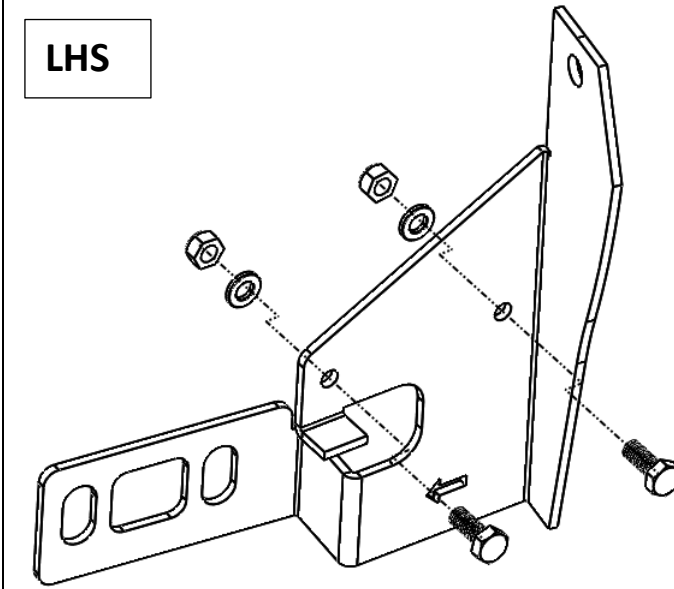
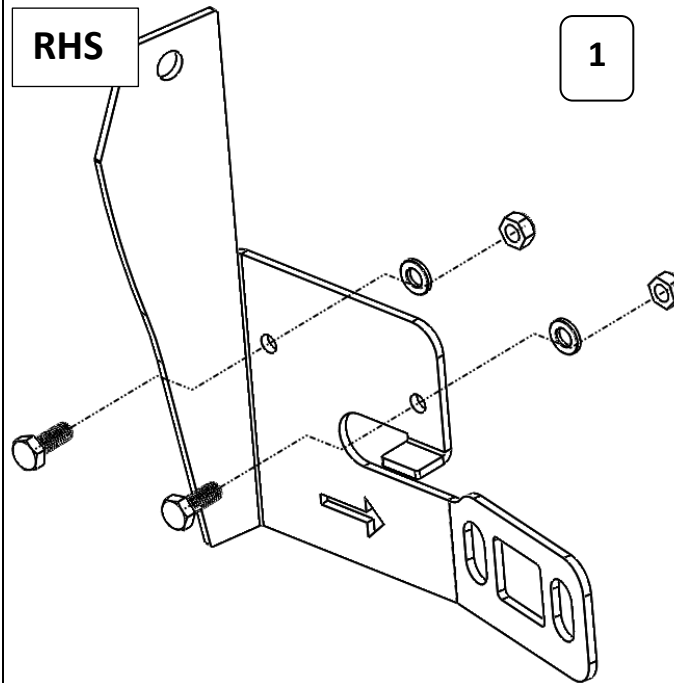

DAMPER MOUNTING SEQUENCE

5. Install the reservoir bracket as shown in (5)
6. Fit the reservoir bracket to the forwards side of the shock tower.

Arrow on bracket faces to front of vehicle

 6151546, 28 N.m (20 ft.lbf)

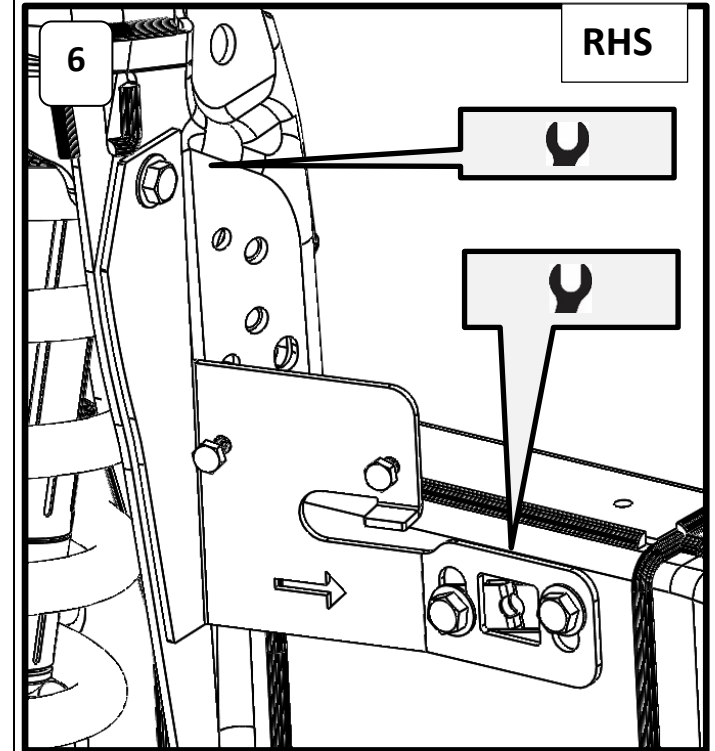
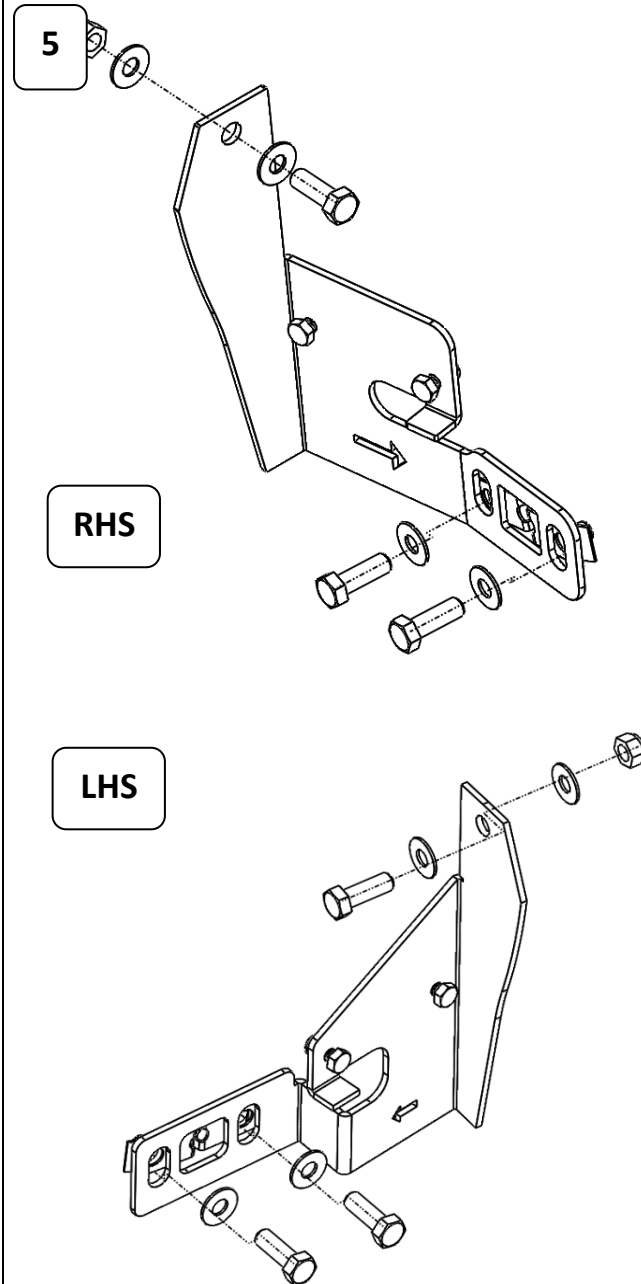

DAMPER MOUNTING SEQUENCE

NOTE:

BP-51 hose is orientated towards the front of the vehicle.

Top Mount:

7. Install the damper and secure the top mount with bolts and washers as shown in the pictures and diagram. Finger tight only.

Bottom Mount:

8. Install the M12 Flange bolts in the lower strut mount and secure using the flange nuts supplied
Finger tight only
9. Slide the reservoir clamp over the reservoir and affix to the reservoir clamp
Space the body 15mm to 25mm as shown

 VD60030003, 12 N.m (9 ft.lbf)

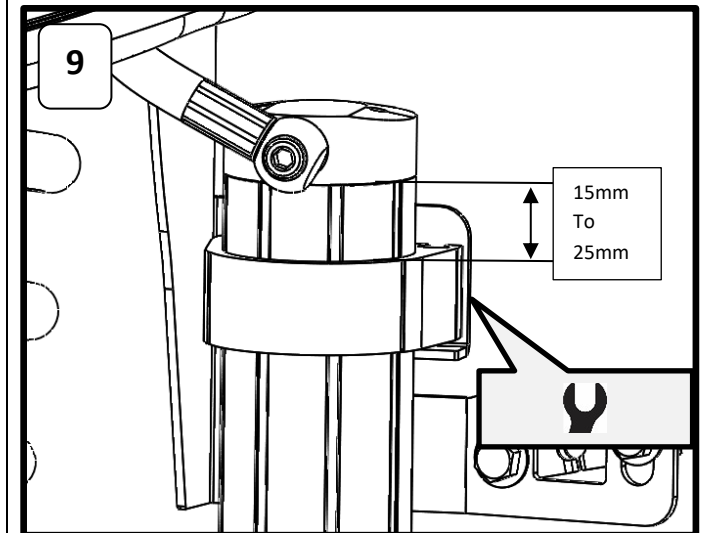
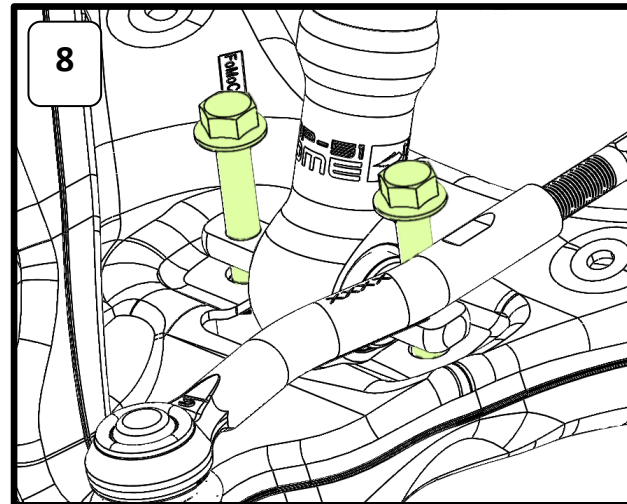
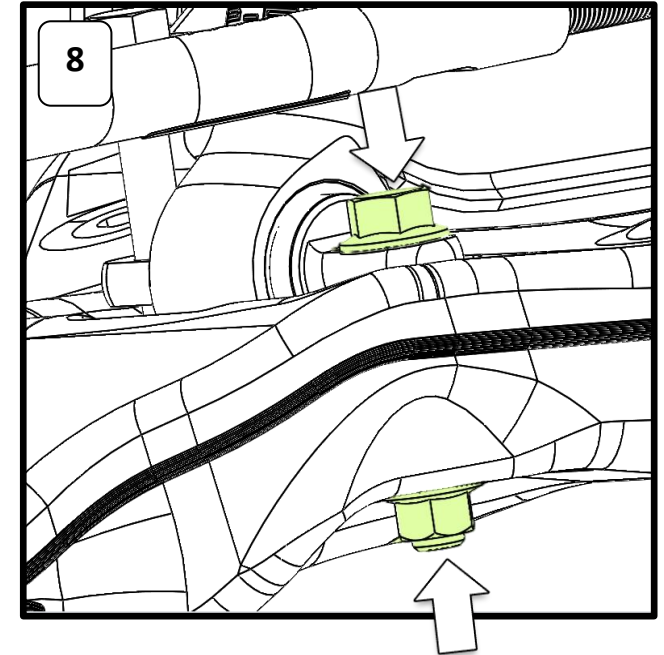
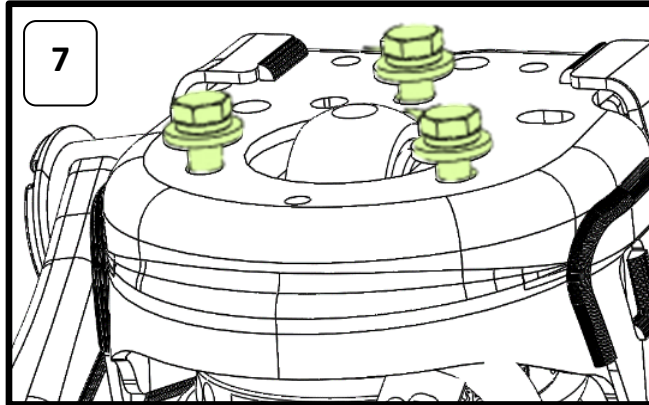

DAMPER MOUNTING SEQUENCE

10. Reattach all the components to the vehicle in the reverse way of detaching them

- a) Upper control arm
- b) Sway bar link
- c) Lower strut bolts
- d) Top strut turret
- e) Tie rod to steering knuckle

Fastener Torque settings

Fastener	Torque N.m (ft.lbf)
Upper Control Arm	63 (46)
Sway Bar Link	175 (129)
Steering tie rod to steering knuckle (CAST IRON)	63(46)
Steering tie rod to steering knuckle (ALUMINIUM)	48(35)
Top Shock Tower	44 (32)
Lower Shock Cross Pin and Nut	100 (73)
Lower Strut bolts	120 (88)
Resi Bracket to Tower	28(20)

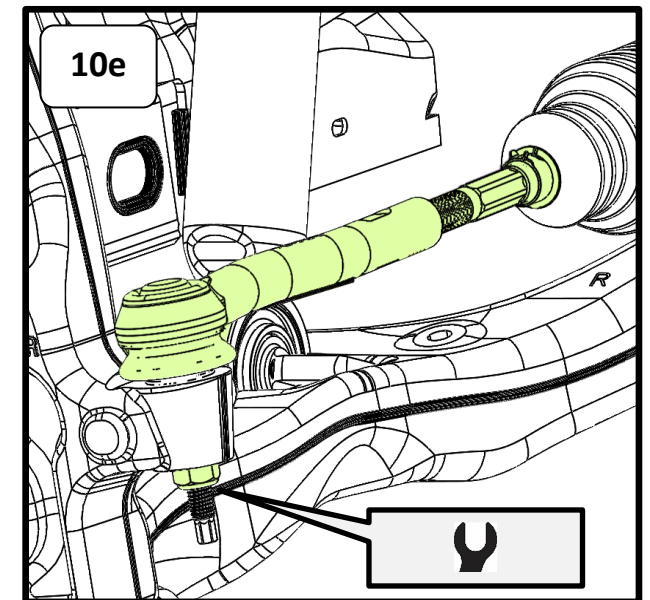
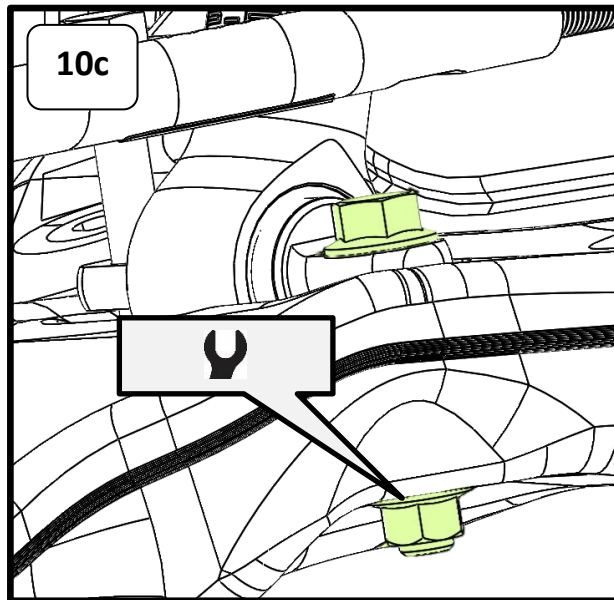
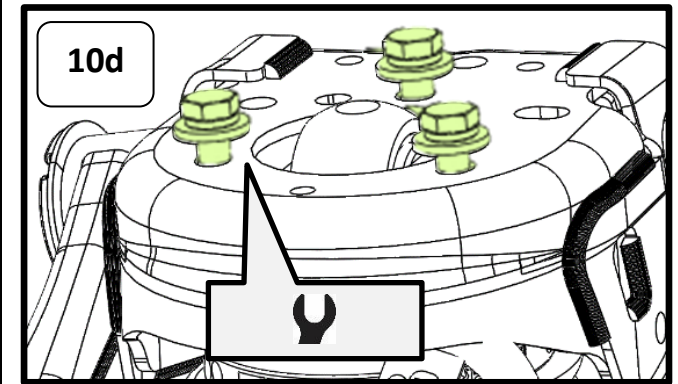
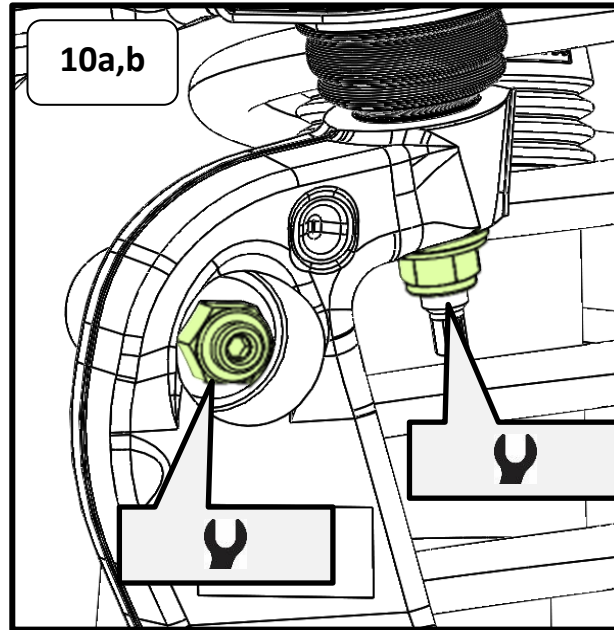

DAMPING ADJUSTMENT

These dampers have been set in the factory to be used for a vehicle with Bull Bar and Winch fitted.

If your accessory fitment differs, use the table below as a guide for recommended Compression and Rebound adjuster settings.

Refer to the Owner's Manual for more information.

Front Accessories	Compression	Rebound
Factory setting	3	6
Bar & winch	4-8	6-10
Bar only	2-6	5-9
No accessories	0-4	4-8

SPECIFICATIONS

1	Extended Length	569 mm
2	Compressed Length	437 mm

SPARE PARTS

Refer to Service and Parts manual, section: **BP-51 S&P 3.1-BP5190015L&R.**

