

# FITTING INSTRUCTIONS

## BP5190019L & BP5190019R

### TOYOTA LC300 FRONT

### WARNING

- ◆ This product must be installed exactly as per these instructions using only the hardware supplied.
- ◆ In the event of damage to any suspension component, contact your nearest authorised ARB stockist. Repairs or modifications to the suspension system components must not be attempted.
- ◆ Do not use this product for any vehicle make or model, other than those specified by ARB.
- ◆ Do not remove labels from suspension components.
- ◆ This product or its fixing must not be modified in any way.
- ◆ The installation of this product may require the use of specialized tools and/or techniques
- ◆ It is recommended that this product is only installed by trained personnel
- ◆ These instructions are correct as at the publication date. ARB Corporation Ltd. cannot be held responsible for the impact of any changes subsequently made by the vehicle manufacturer
- ◆ During installation, it is the duty of the installer to check correct operation/clearances of all components
- ◆ Work safely at all times

**Note:** These fitting instructions should be read in conjunction with the vehicle workshop manual.

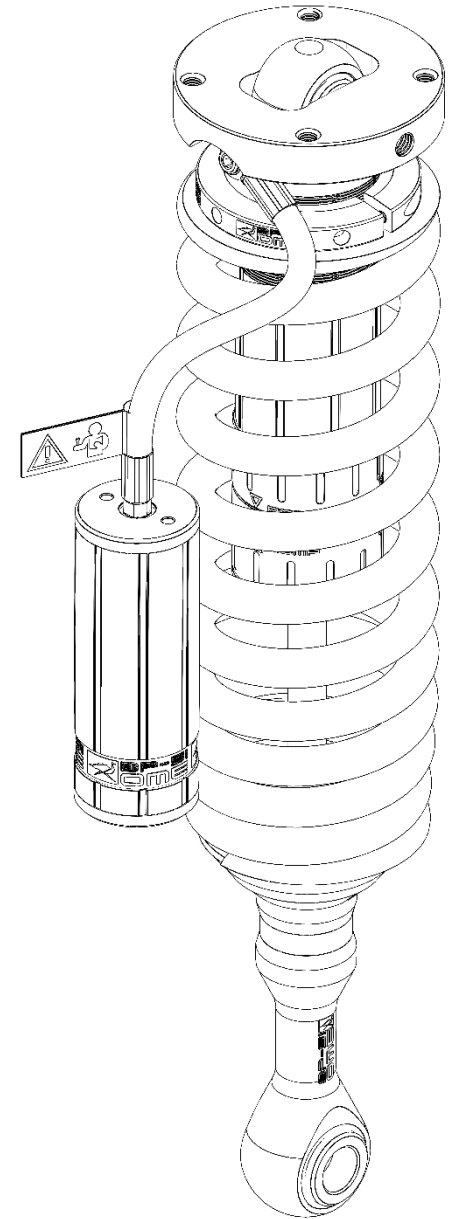

**FITTING KIT CONTENTS – VM80010054**

Item	Description	Qty.	Part No.
1	LC300 RESI BRACKET FRONT RIGHT (SHOWN)	1	VE10020044R
2	LC300 RESI BRACKET FRONT LEFT	1	VE10020044L
3	RESERVOIR CLAMP	2	VE10010003
4	FASTENER KIT	1	VM60010045
	4.1 M6 X 16MM BOLT	4	VD60030003
	4.2 M6 WASHER	4	VE70020005
	4.3 M6 NYLOCK NUT	4	VD60010003
	4.4 M10 WASHER	4	4584366
	4.5 M10 X 1.5 X 30 BOLT KIT	8	6151555
5	TOOL: ADJUSTER TOOL	1	VC10010071

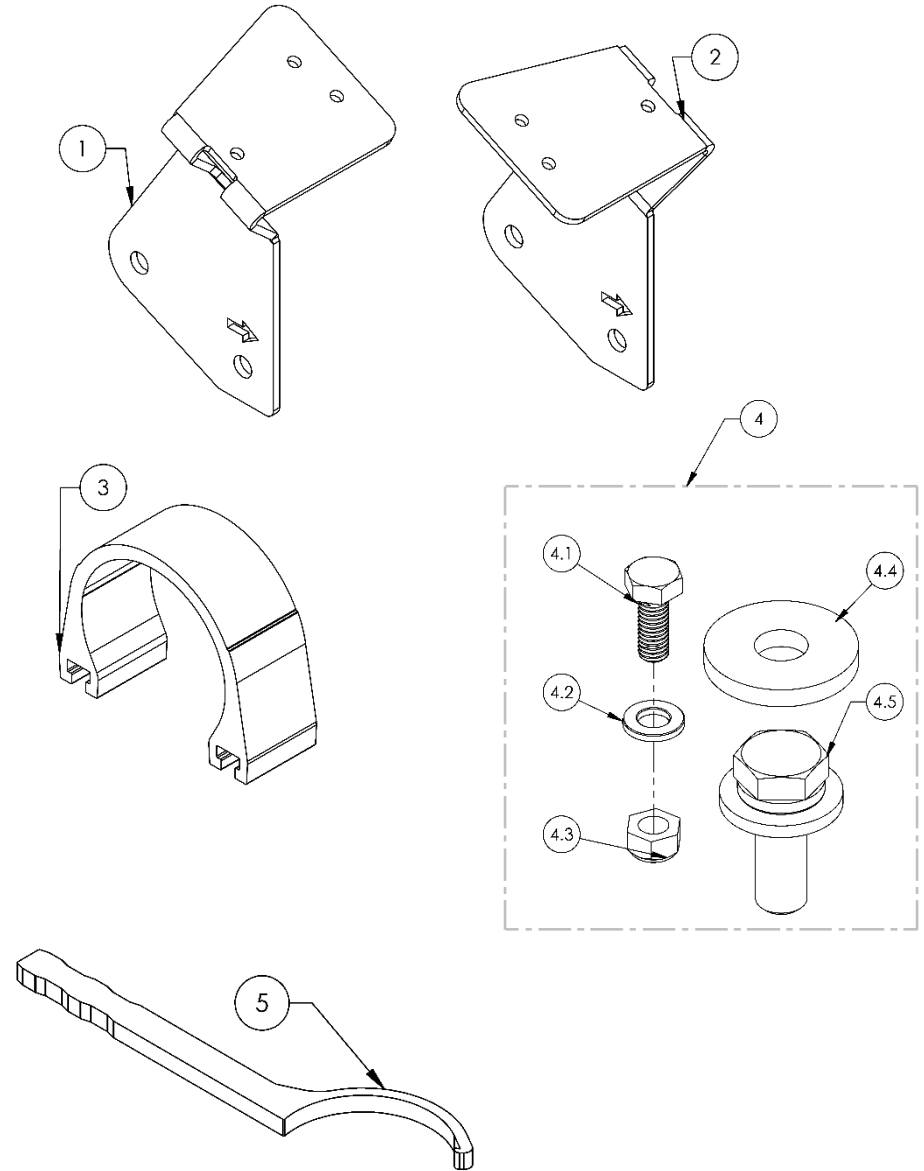

## DAMPER PREPARATION

Before fitment the spring preload may need to be adjusted to suit your front accessory fitment and desired ride height.

Use workshop tool kit **VM80020001** to aid spring adjustment.

The spring preload is set at the factory to 20mm as shown by the diagram.

This aims to achieve 40-50mm increase in ride height over OE when a Bull Bar and winch are fitted.

It is required to set the preload before the strut assembly is fitted to the vehicle. Use a spring compressor to compress the spring, loosen the pinch bolt on the preload ring and adjust to the desired setting. Tighten the pinch bolt and remove the strut assembly from the spring compressor.

As a guide, set the preload as specified below to achieve 40-50mm lift over OE.

Front accessories	Preload	
	Diesel	Petrol
Bar, winch +	25mm	20mm
Bar & winch	20mm	15mm
Bar only	15mm	10mm
No accessories	5mm	0mm

**Spring preload must only be adjusted when a spring compressor is used to take load off the preload ring.**

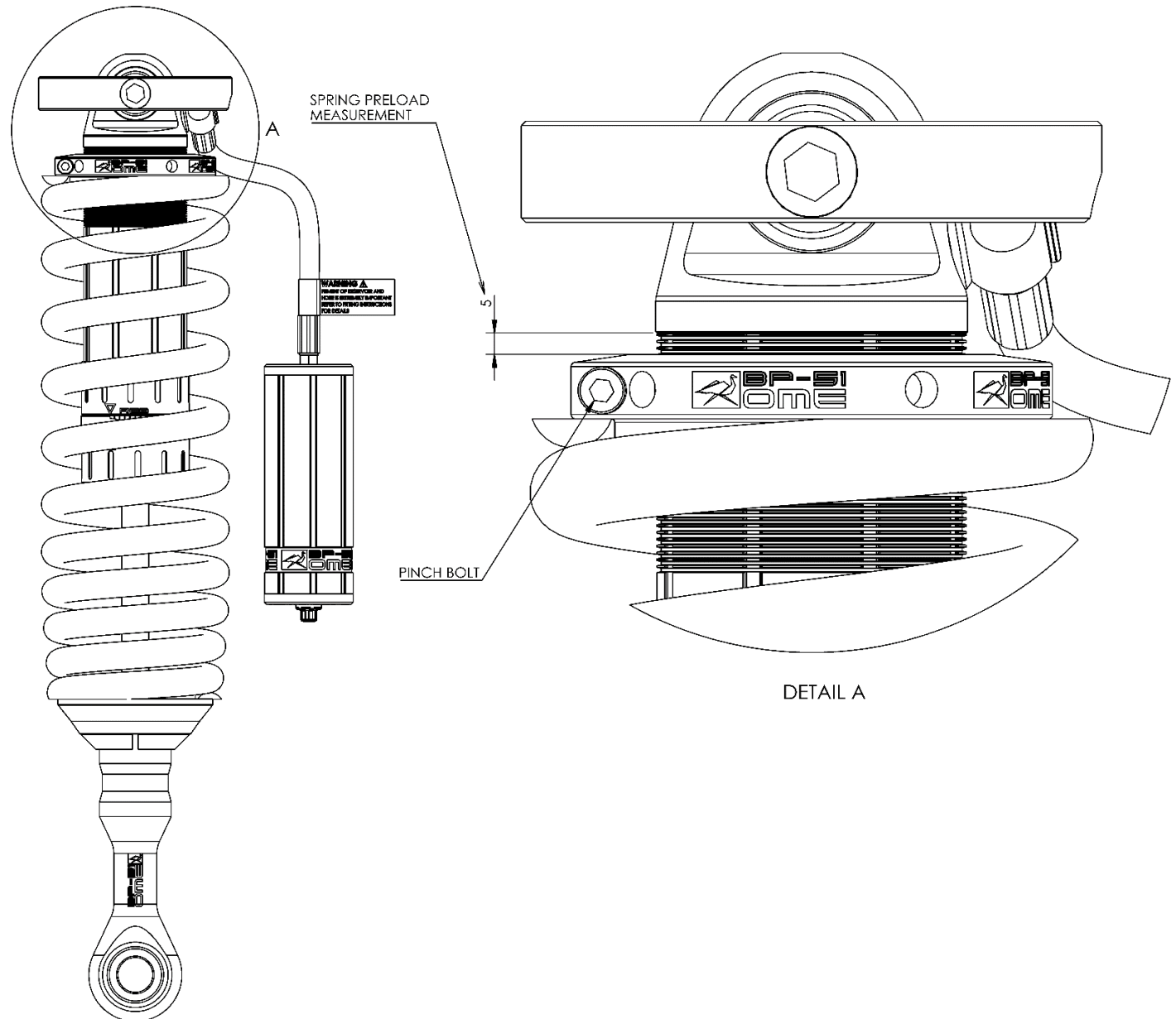

### DAMPER MOUNTING SEQUENCE

1. Remove wheel
2. Remove sway bar links and retain to refit
3. Unbolt sway bar from chassis
4. Remove tie rod
5. Remove lower strut bolt

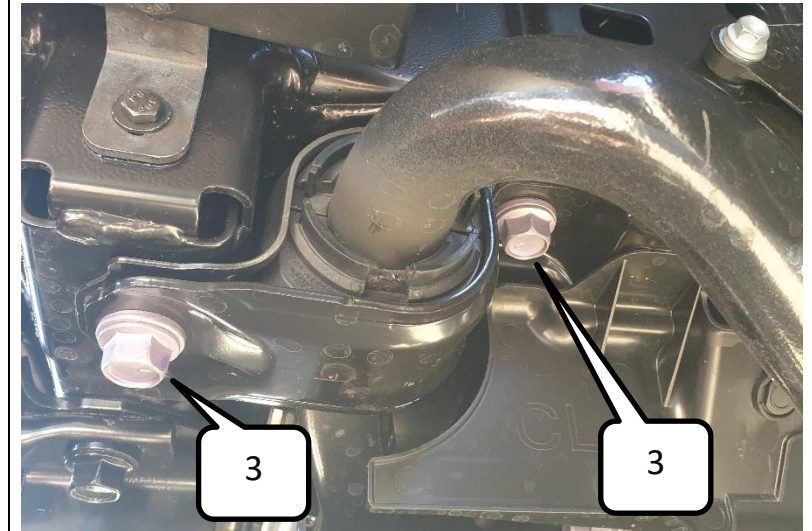
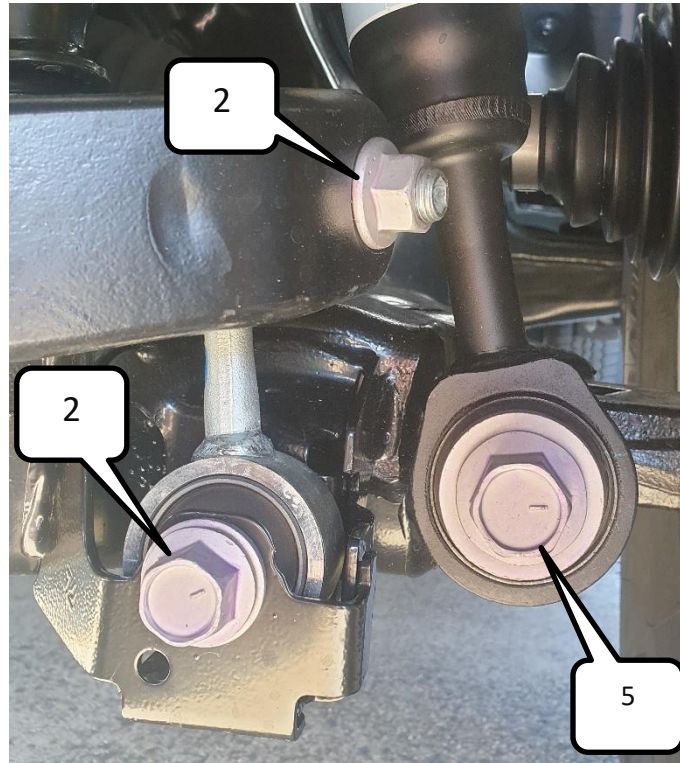

LHS SHOWN, RHS IDENTICAL

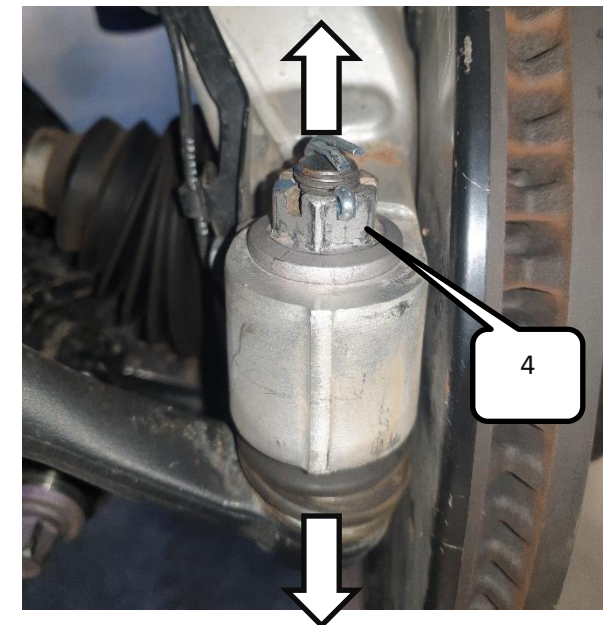

6. Move sway bar sideways so the strut can be removed
7. Unscrew OE strut top hat nuts
8. Remove the OE strut

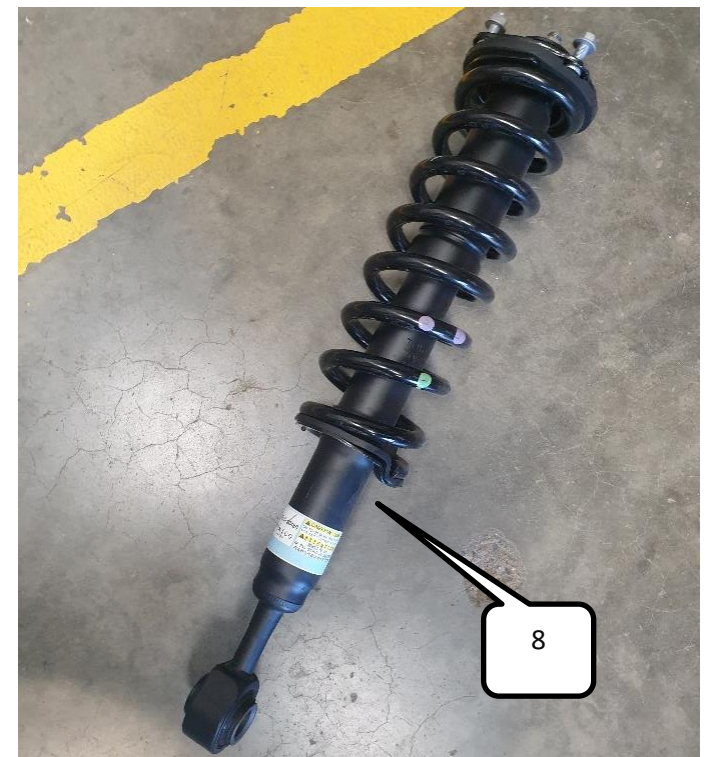
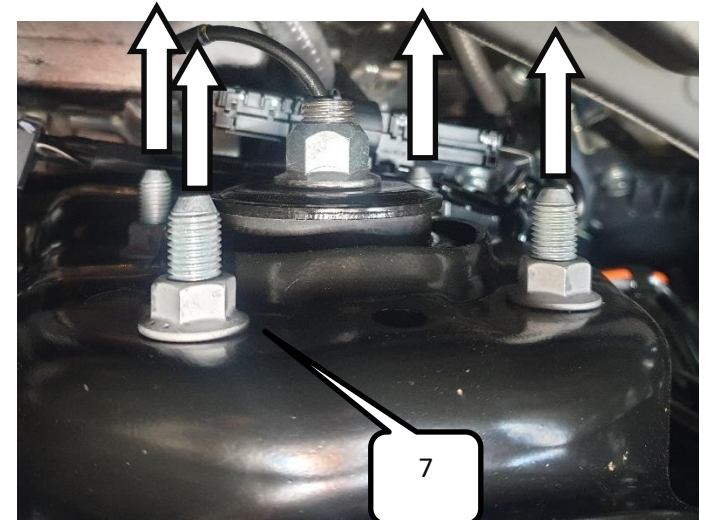
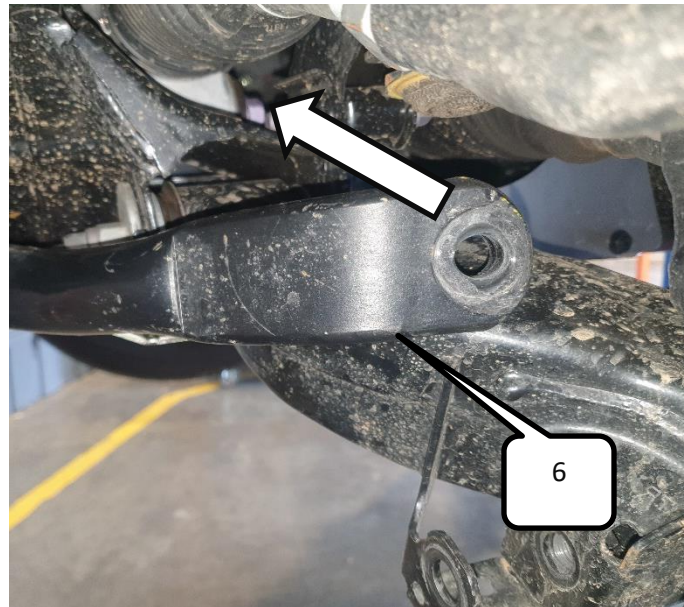
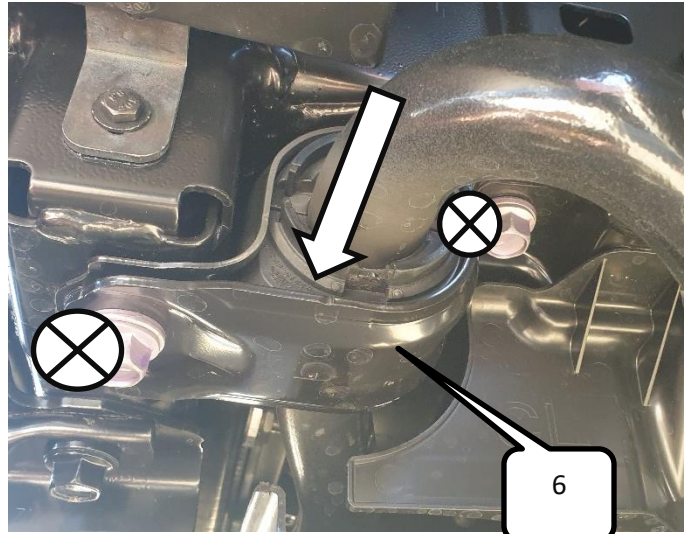

## BUMP STOP SPACER

1. Remove the lower control arm bump stops using multi grips
2. Place 4584366 on the bump stop thread
3. Reinstall on the chassis

 Bump Stop, 45 N.m (33 ft.lbf)

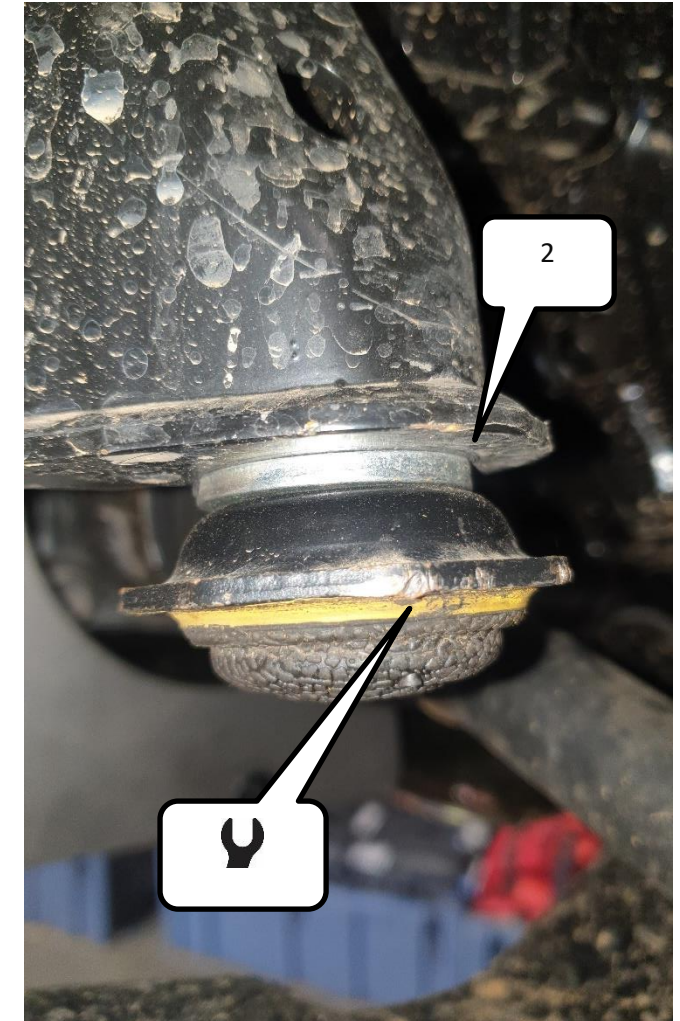
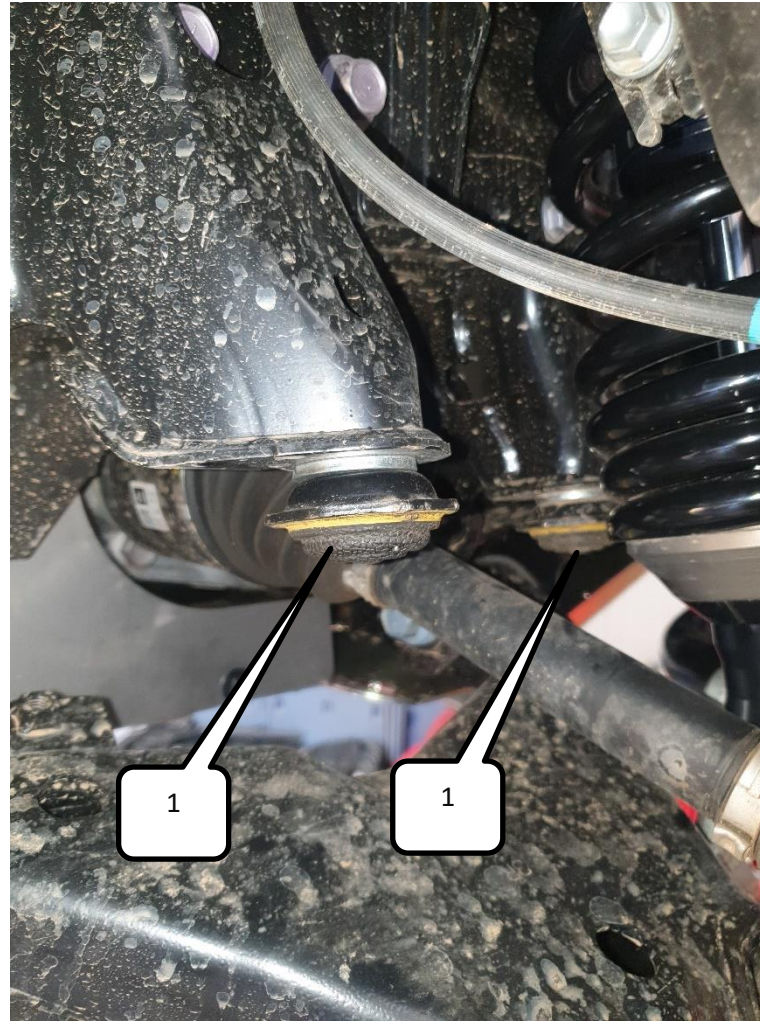

### DAMPER MOUNTING SEQUENCE

Fit the damper and secure the top mount with the M10 hardware supplied. Secure finger tight. (RH shown)

When mounted in the vehicle the hose and reservoir should be towards the front.

Damper is supplied with reducers and o-rings fitted.

Fit bottom mount to lower control arm.

Secure bottom mount using original bolt

Torque all fasteners as per diagram and table below.

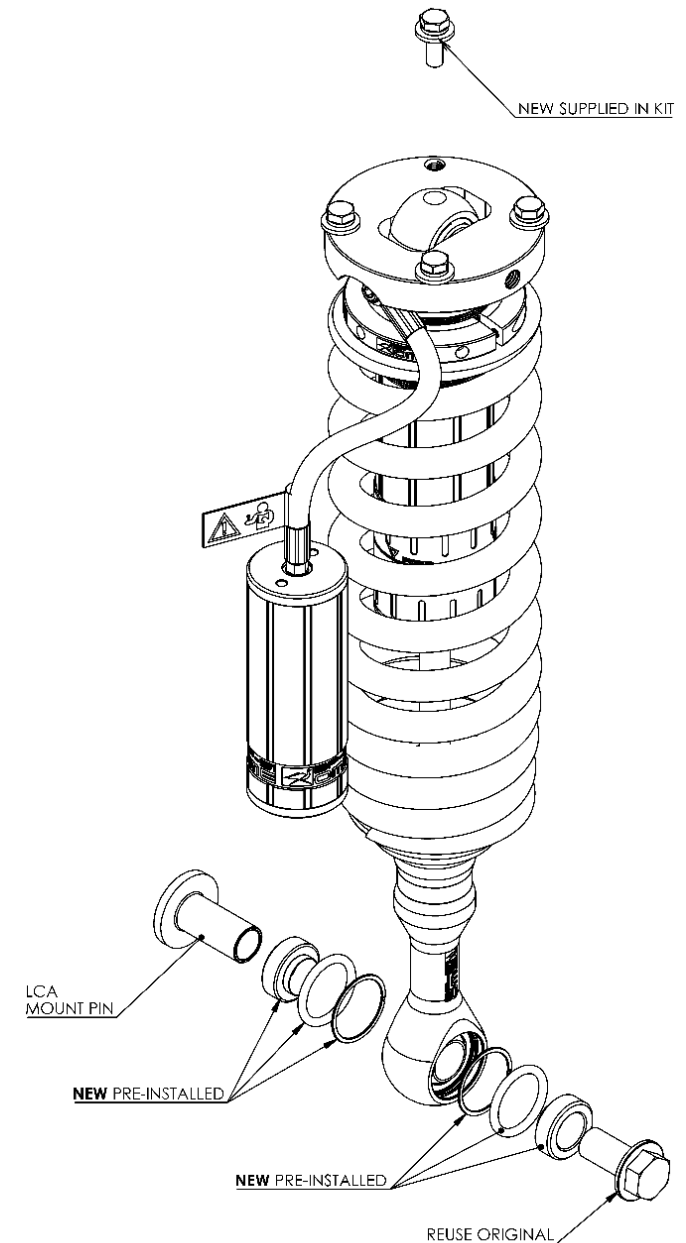

	Fastener	Torque N.m (ft.lbf)
1	Steering tie rod end to Knuckle	120 (88)
2	Strut top hat	44 (32)
3	Sway bar link to Sway bar	128 (95)
4	Strut to lower control arm	250 (184)
5	Sway bar link to lower control arm	140 (103)
6	Bump stop	45 (33)
7	Sway bar saddle	87(65)



1 

2 

3 

4 

5 

6 

7 

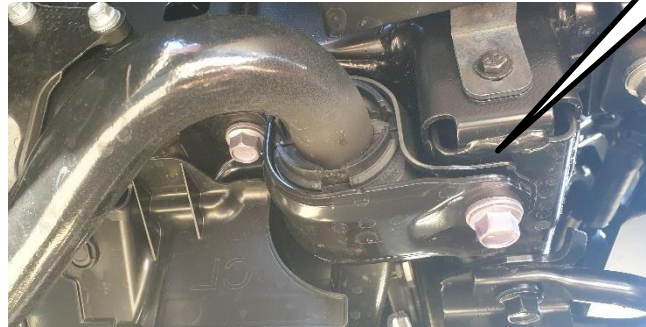



## RESERVOIR MOUNTING SEQUENCE

Fit M6 hardware to bracket shown with washers fitted on the nut side. Secure finger tight only.

Fit the mounting bracket to the chassis, behind the plastic guard as shown. Reuse existing bolts to secure the bracket. Tighten securely.

Fit the mounting clamp to the reservoir and slide assembly over the head of the bolts fitted to the mounting bracket.

Align the reservoir so that the clamp is 40mm to 50mm from the end as shown. Securely fasten the M6 nyloc nuts using a 10mm spanner. (ring or ratchet spanners work best)

Ensure the hose is well routed from the damper body cap to the reservoir without kinks and with clearance to the upper control arm.

Refit the original shroud over the reservoir using the original fasteners.

 Stone Guard, 25 N.m (18 ft.lbf)

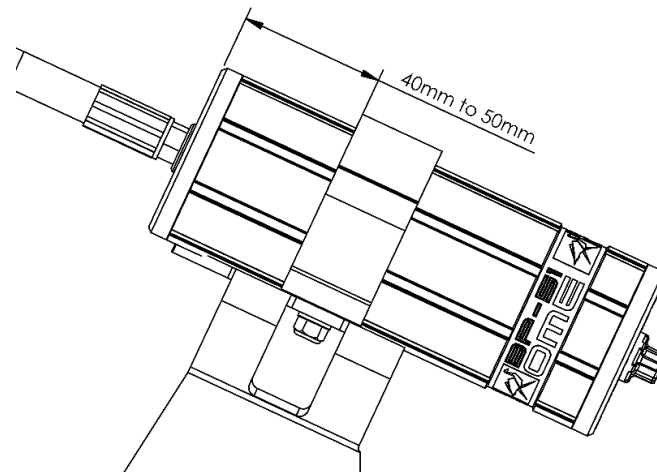
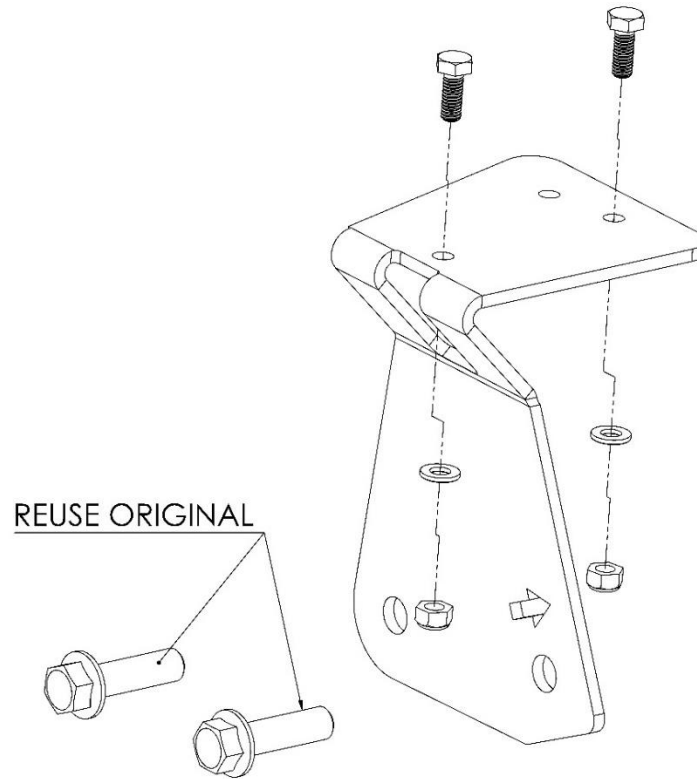

## DAMPING ADJUSTMENT

These dampers have been set in the factory to be used for a vehicle with Bull Bar and Winch fitted.

If your accessory fitment differs, use the table below as a guide for recommended Compression and Rebound adjuster settings.

Refer to the Owner's Manual for more information.

Front Accessories	Compression	Rebound
Factory setting	5	6
Bar & winch	5-10	7-10
Bar only	2-8	6-10
No accessories	0-6	4-7

## SPECIFICATIONS

Extended Length	615 mm
Compressed Length	469 mm

## SPARE PARTS

Refer to Service And Parts Manual, section: **BP-51 S&P 3.1-BP5190019L&R.**

