

FITTING INSTRUCTIONS

BP5190061, BP5160062 & BP5160066

TOYOTA LANDCRUISER 300 REAR

WARNING

- ◆ This product must be installed exactly as per these instructions using only the hardware supplied.
- ◆ In the event of damage to any suspension component, contact your nearest authorised ARB stockist. Repairs or modifications to the suspension system components must not be attempted.
- ◆ Do not use this product for any vehicle make or model, other than those specified by ARB.
- ◆ Do not remove labels from suspension components.
- ◆ This product or its fixing must not be modified in any way.
- ◆ The installation of this product may require the use of specialized tools and/or techniques
- ◆ It is recommended that this product is only installed by trained personnel
- ◆ These instructions are correct as at the publication date. ARB Corporation Ltd. cannot be held responsible for the impact of any changes subsequently made by the vehicle manufacturer
- ◆ During installation, it is the duty of the installer to check correct operation/clearances of all components
- ◆ Work safely at all times

Note: These fitting instructions should be read in conjunction with the vehicle workshop manual.

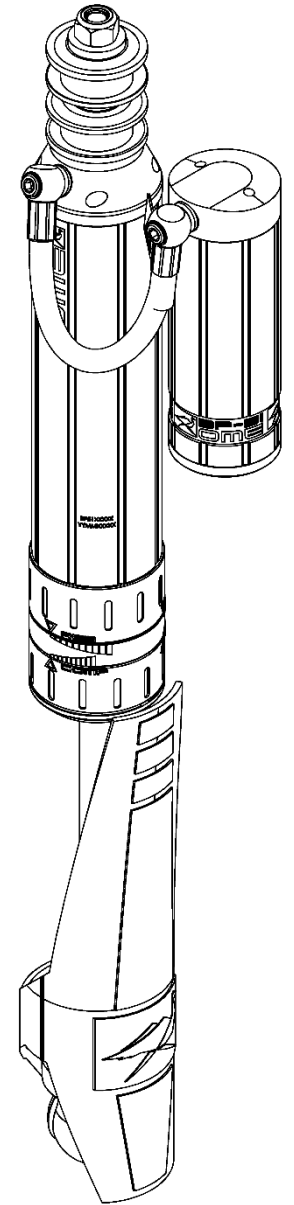

FITTING KIT CONTENTS – VM80010067

Item	Description	Qty.	Part No.
1	BRKT 300 SERIES REAR LH	1	VE10020047
2	BRKT 300 SERIES REAR RH	1	VE10020048
3	BP-51 FASENER KIT LC300 REAR		VM60010048
	3.1 BOLT M6 X 10	4	VD60030003
	3.2 M6 WASHER	4	VE70020005
	3.3 NUT HEX NYLOC M6	4	6151223
	3.4 FLAT WASHER M12	2	4581011
	3.5 WASHER ID19OD 46 T2	2	VE70020006
	3.6 BOLT HXHD FL M12x1.25x35	4	6151545
4	ADJUSTER TOOL		VC10010071
5	RESERVOIR MOUNT CLAMP	2	VE10010003

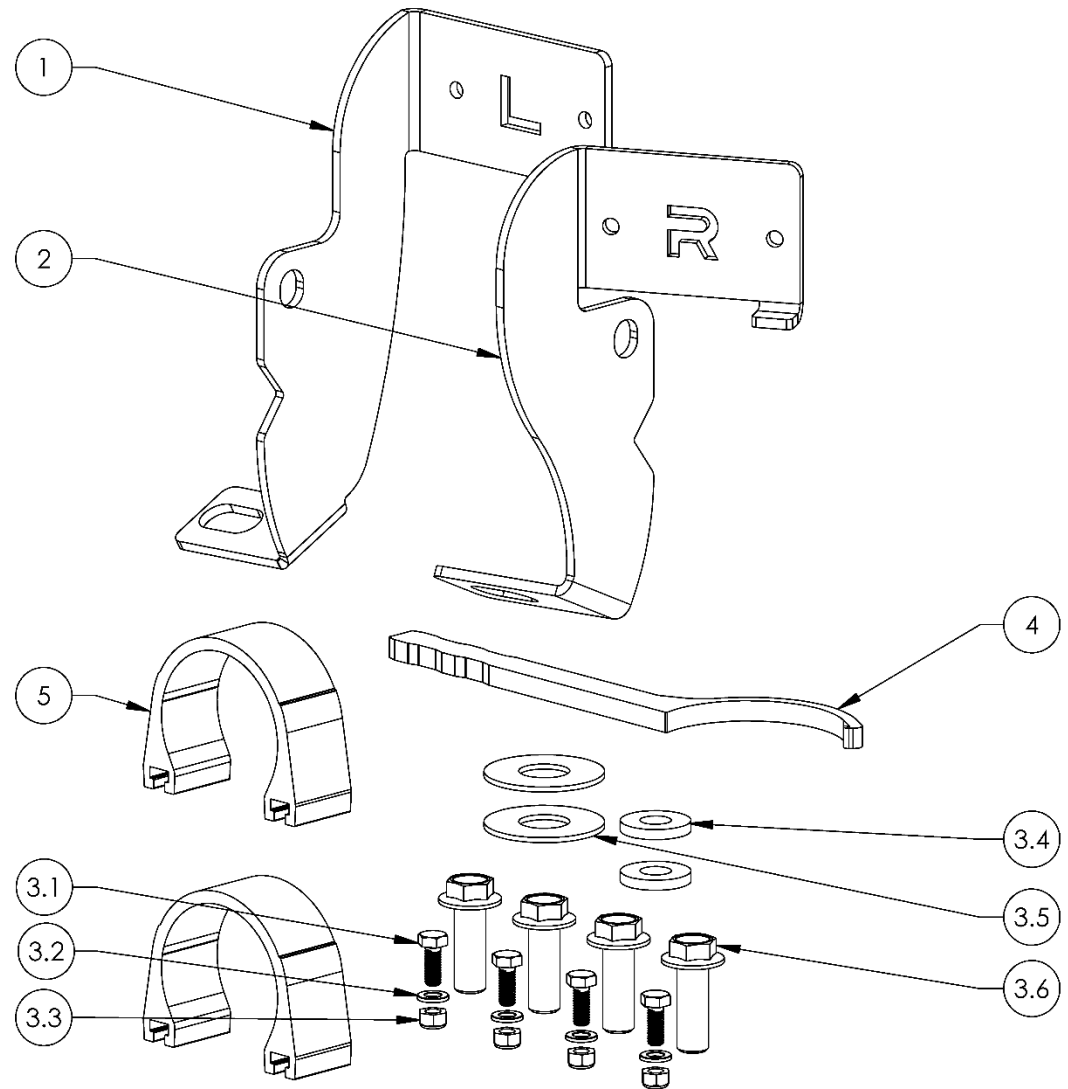

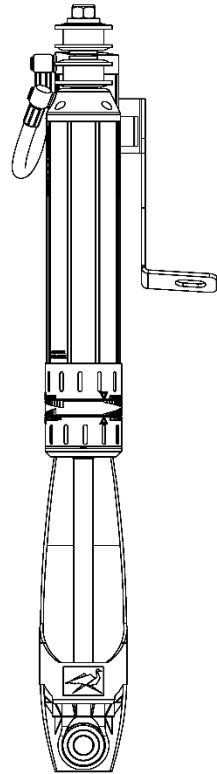
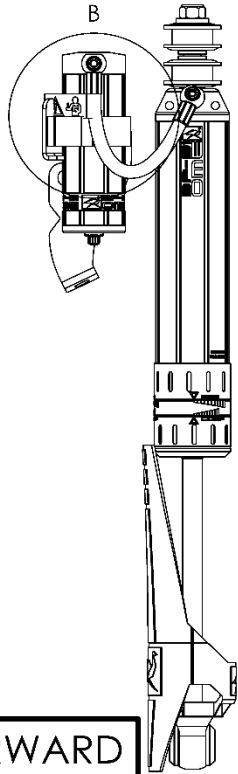
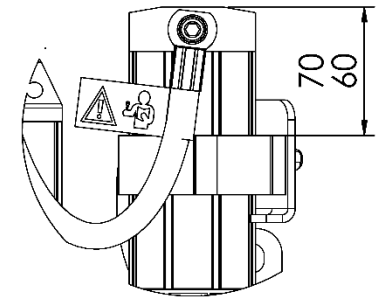
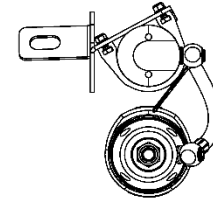
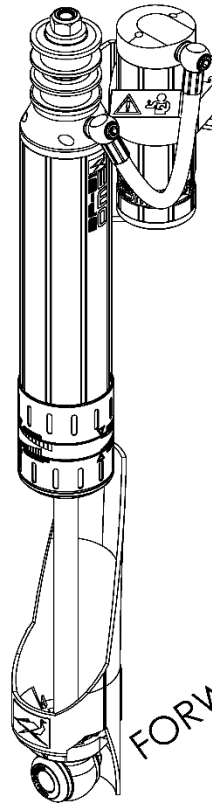
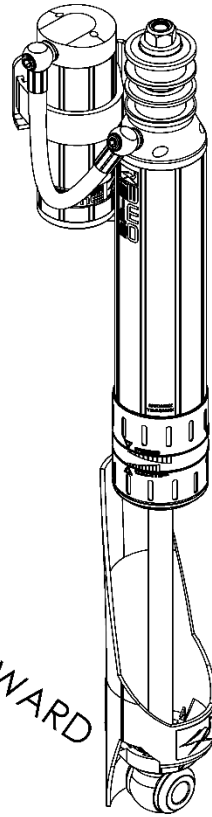
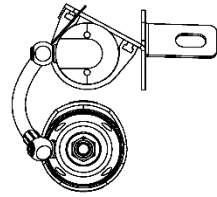
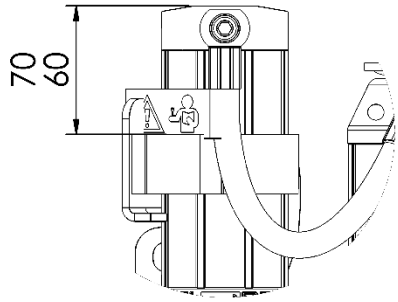

FORWARD

FORWARD

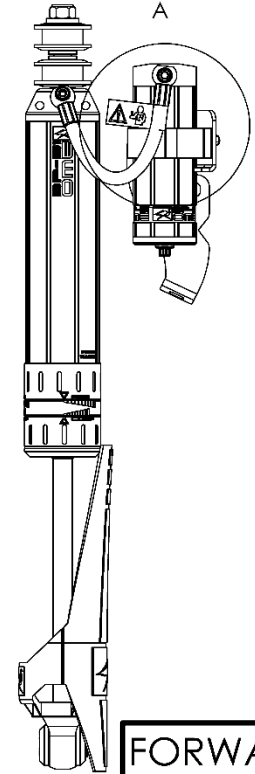
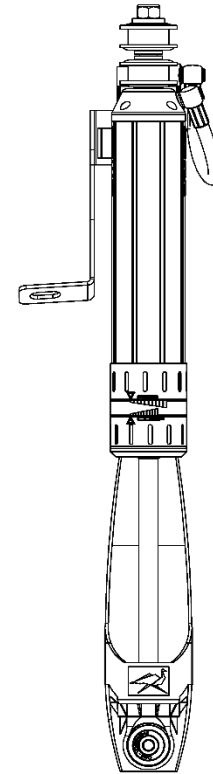

LHS

RHS

VEHICLE PREPARATION

Remove the following to avoid damage during installation of the BP-51's and coil springs.

1. Hard brake line hose (x3) rear of diff
2. Hard to flexible brake line mount above diff
3. Flexible brake line on cross member
4. Handbrake line on cross member
5. Diff breather bracket on cross member
6. Headlight level sensor (if fitted)

Remove the OE shocks and set aside the OE fasteners for re-use.

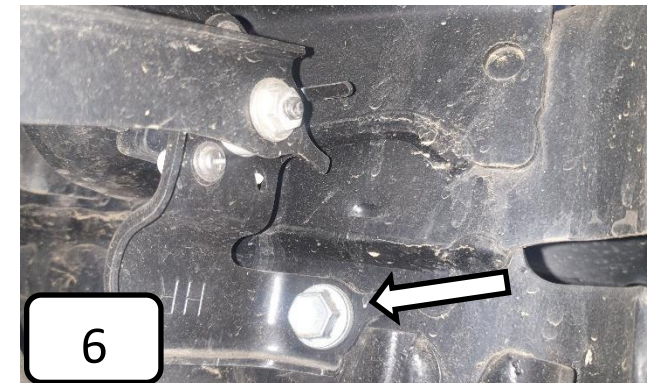
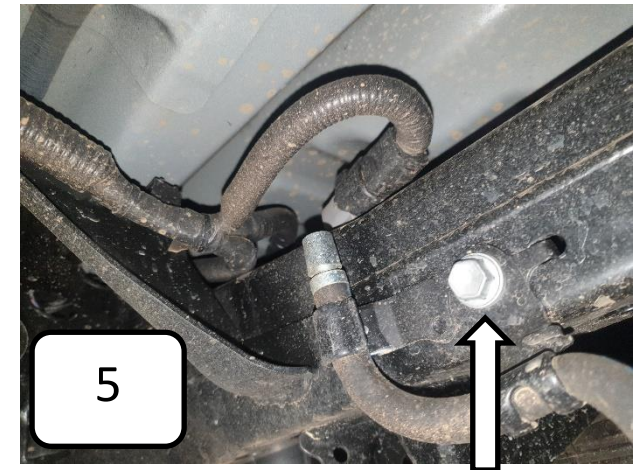
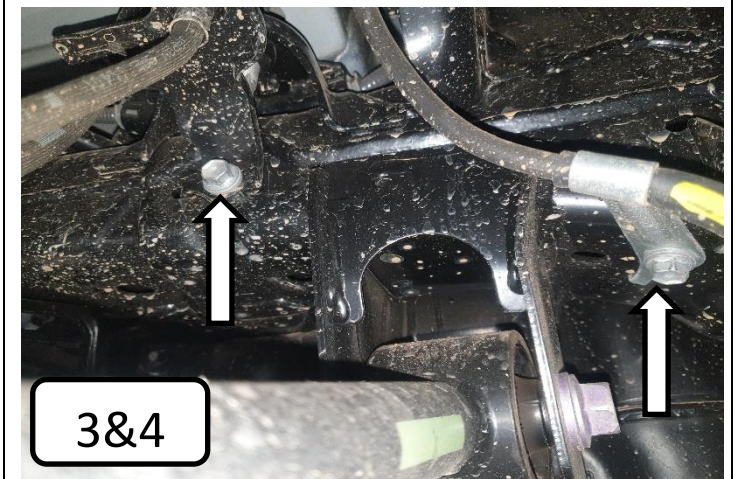
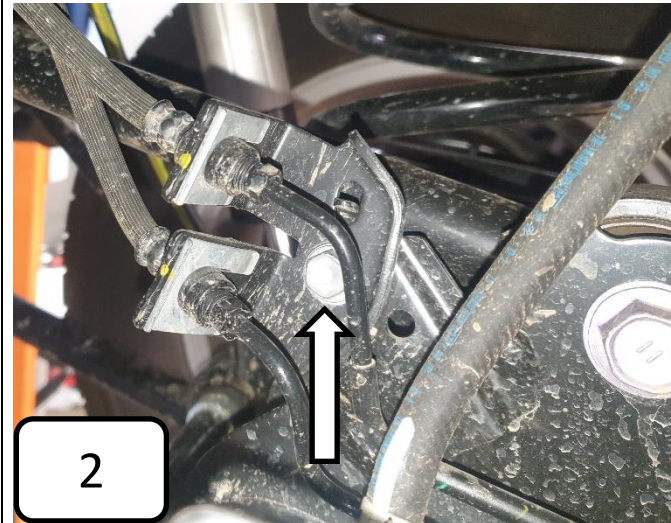
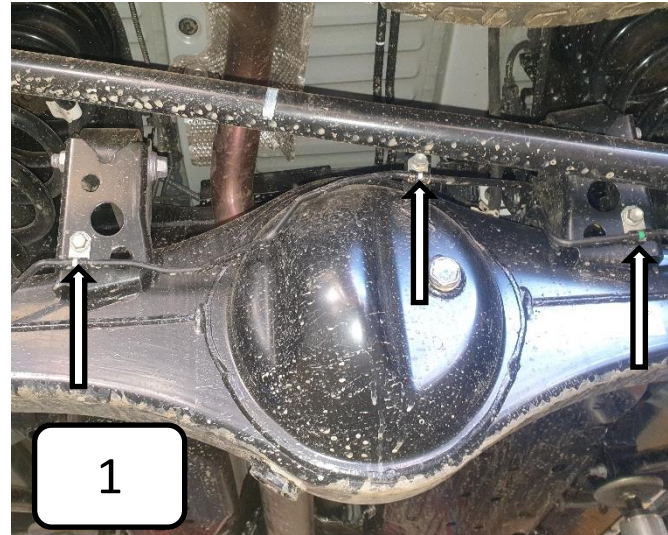

DAMPER MOUNTING SEQUENCE

Top Mount

Note: Fit the top mount such that the hose leaving the damper is pointing towards the front of the vehicle.

1. Fit the bush kit VM50010006 to the pin in the sequence shown by the diagram.
2. Fit damper to vehicle and secure with remaining top mount hardware.

Bottom Mount

3. Fit the damper and secure with the original hardware as shown.
4. Fit the two shaft guard retainers to the eyelet and secure by firmly pulling the guard down over the retainers. Refer to next page for more detail.
5. Torque fasteners as specified.

 **Top Damper Nut: 98N.m (72 ft.lb)**

 **Bottom Damper Bolt: 98N.m (72 ft.lb)**

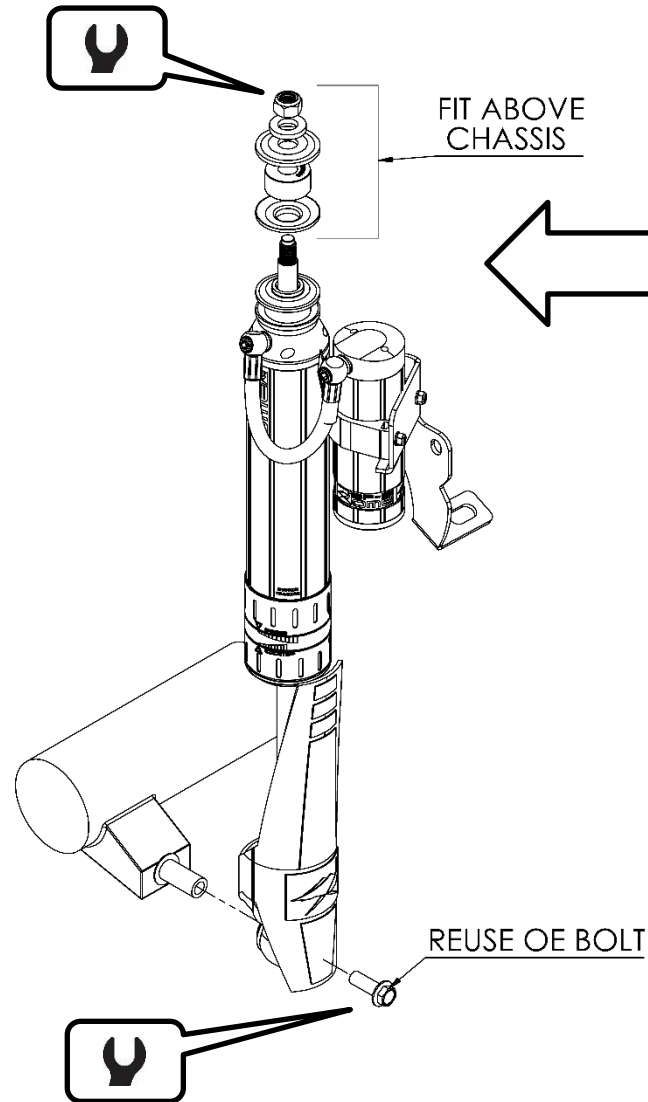

BUSH KIT VM50010006

VD60010007

VE70020013

VF60020004

VD50030003

VF60020002

VF60020002

VD50030003

VF60020004

SECURING SHAFT GUARDS

The shaft guards are designed to protect the shaft from stones thrown from the front wheels and are mounted to the front side of the damper.

It is easiest to secure the shaft guards before the dampers are fitted to the vehicle.

Please follow steps 1-3.

1. Fit the two retainers to the eyelet as shown. Note the orientation.

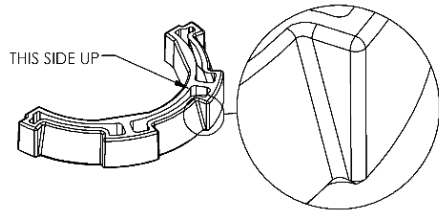

2. There are features on the shaft guard that locate in the gaps between the two retainers. Align the guard with these gaps and firmly pull the shaft guard down over the retainers to secure in place.

3. Check retainers are completely secured by guard. Use a flat blade screwdriver to poke retainers under tabs on guard if required. Refer to pictures (A) and (B) for correct fitment.

IMPORTANT: Ensure ALL tabs are fully retained.

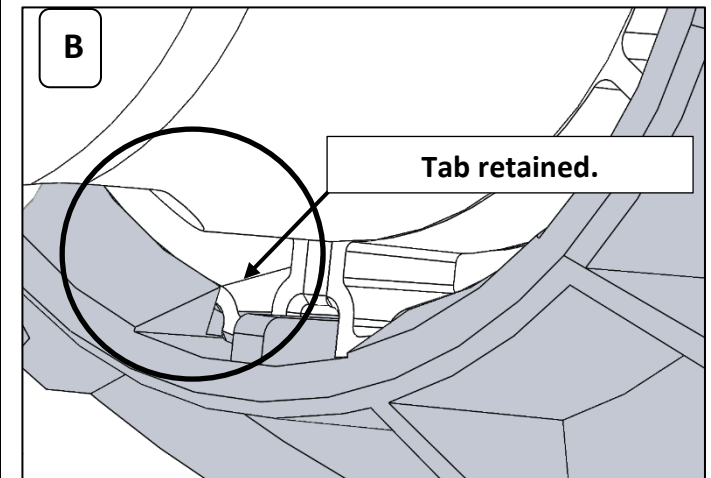
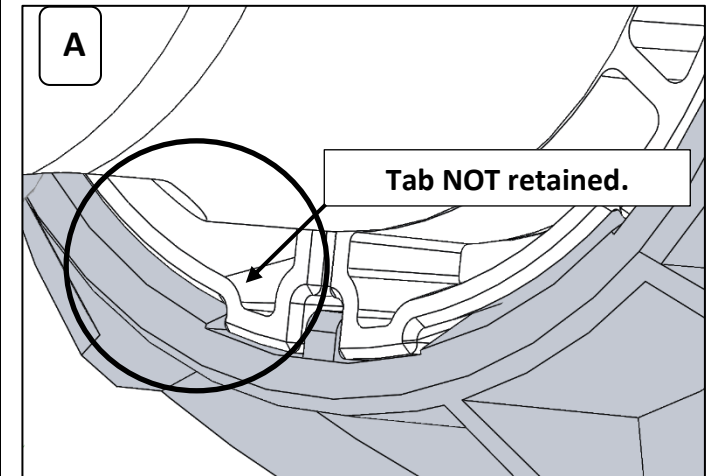
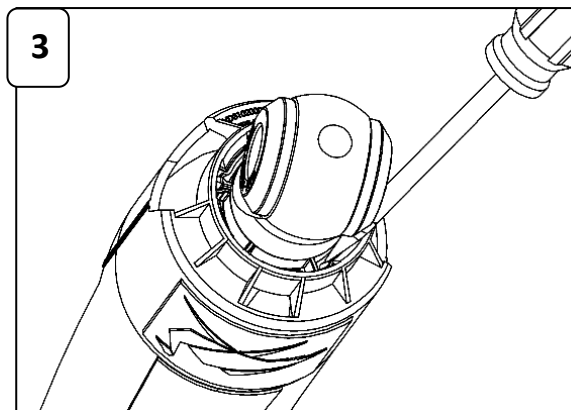
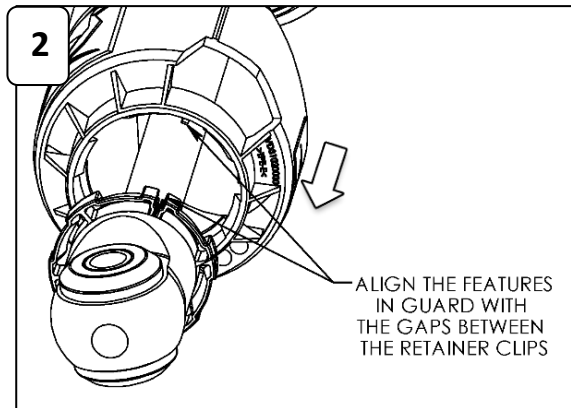
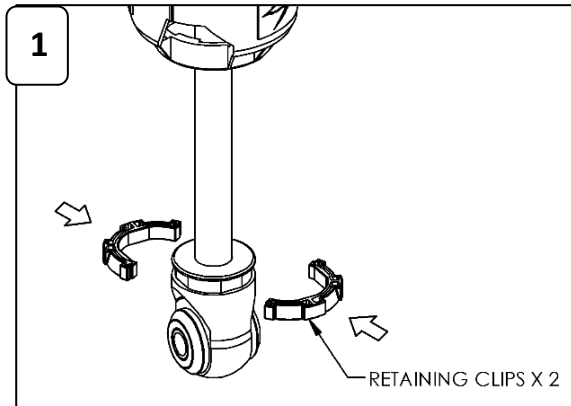

IMPORTANT: Ensure ALL tabs are fully retained

RESERVOIR MOUNTING SEQUENCE

1. Remove bolts securing sway bar link bracket to chassis. (This step not required for KDSS models)
2. Fit reservoir mounting bracket to the outside of the sway bar link bracket where present.
3. Place 4581011 washer between lower sway bar bracket and chassis or between the resi bracket and chassis on KDSS.
4. Secure using the original hardware (or new M12 bolts supplied if fitting to models with KDSS)

 OE Sway bar bolts: 37N.m (27 ft.lb)

Reservoir Mount:

5. Pre assemble the reservoir brackets as shown
6. Lightly fasten the reservoir clamp onto the bracket

 Reservoir clamp 12 N.m (9 ft.lbf)

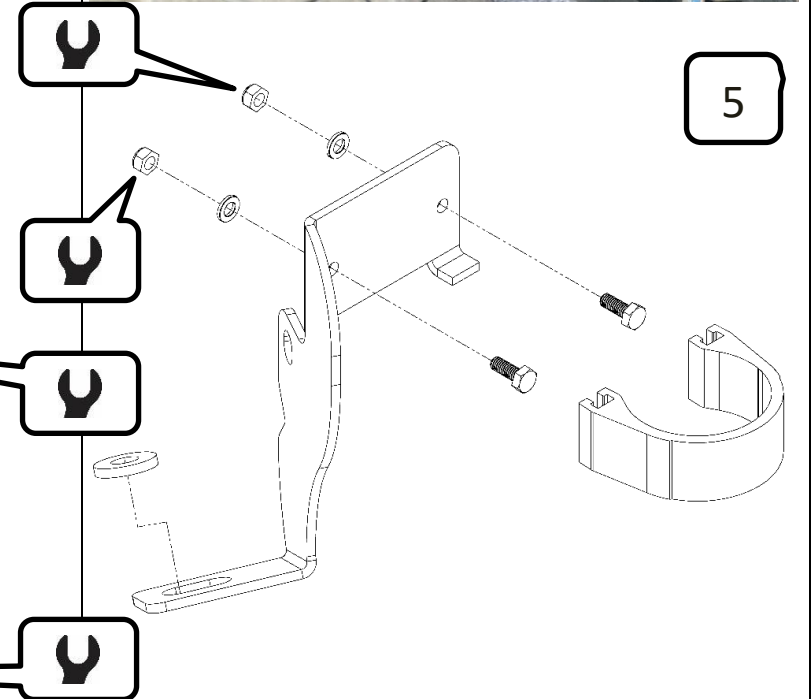
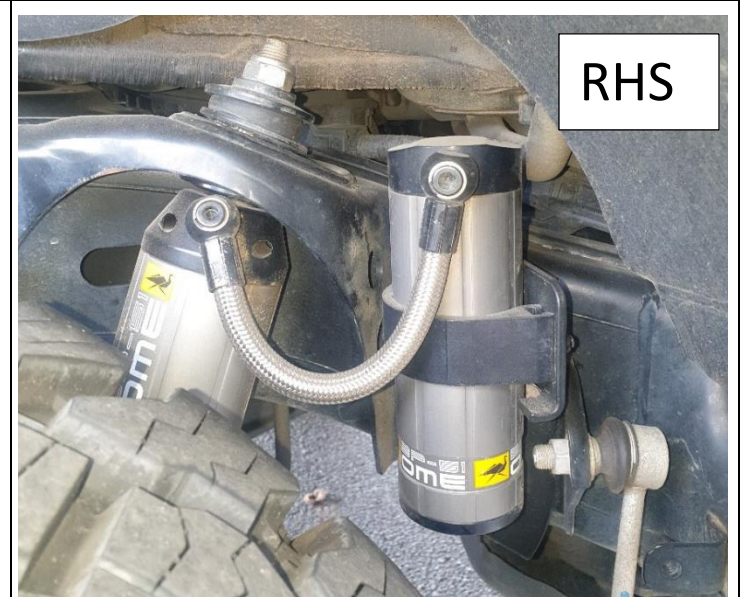
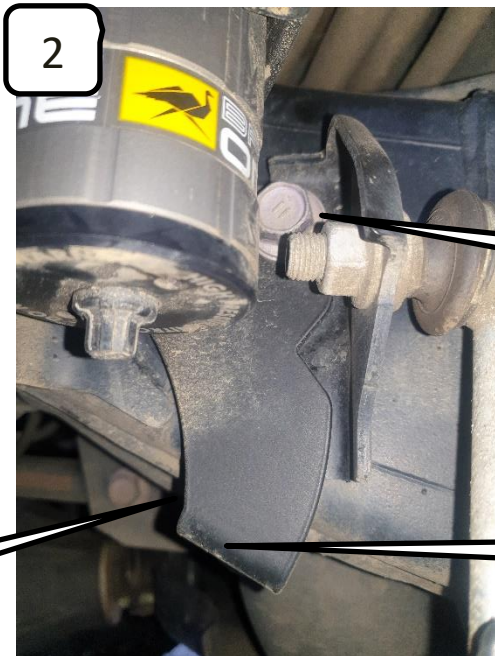
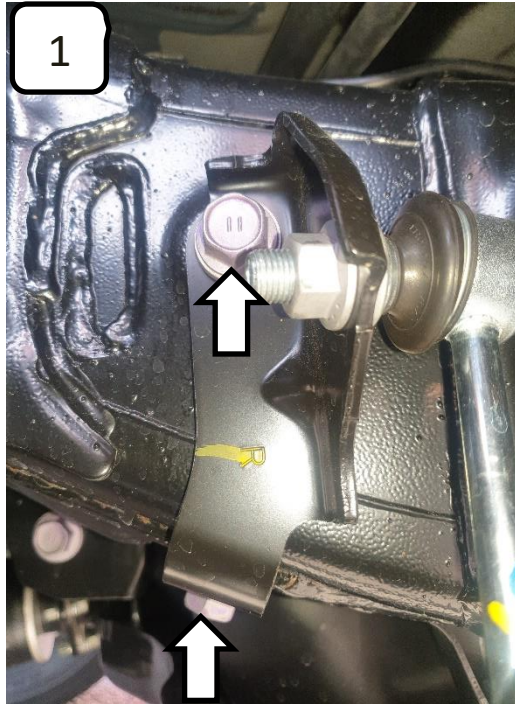

DAMPING ADJUSTMENT

These dampers have been set in the factory to be used for a vehicle with certain load.

If your load or accessory fitment differs, use the table below as a guide for recommended compression and rebound adjuster settings.

Part Number	Rear Pay Load (kg)	Compression	Rebound
BP5160061	0 - 200	0-4	2-6
	200 - 400	3-7	4-8
	400 +	6-10	7-10
BP5160062	200 - 400	5-8	6-10
	400 +	7-10	6-10

SPECIFICATIONS

BP5160061 & BP5160062	Extended Length	664 mm
	Compressed Length	416 mm

SPARE PARTS

Refer to Service & Parts Manual section:

- For BP5160061 see **BP-51 S&P 3.1-BP5160061**
- For BP5160062 see **BP-51 S&P 3.1-BP5160062**

